

LECTURE NOTE
ON
POWER STATION ENGINEERING
DIPLOMA 6th SEM



DEPARTMENT OF MECHANICAL ENGINEERING

PREPARED BY:ER.ABHIJIT DASH

**GANESH INSTITUTE OF ENGINEERING AND TECHNOLOGY
(POLYTECHNIC)**

(Approved by AICTE)

ANDHARUA,BHUBANESWAR

COURSE OBJECTIVES:

At the end of the course the students will be able to:

- Understand the generation of power by utilizing various energy sources.
- Understand the use of steam, its operation in thermal power stations.
- Understand the nuclear energy sources and power developed in nuclear power station.
- Understand the basics of diesel electric power station and hydroelectric power station.
- Understand the basics of gas turbine power station

1.0 INTRODUCTION:

- 1.1 Describe sources of energy.
- 1.2 Explain concept of Central and Captive power station.
- 1.3 Classify power plants.
- 1.4 Importance of electrical power in day today life.
- 1.5 Overview of method of electrical power generation.

2.0 THERMAL POWER STATIONS:

- 2.1 Layout of steam power stations.
- 2.2 Steam power cycle. Explain Carnot vapour power cycle with P-V, T-s diagram and determine thermal efficiency.
- 2.3 Explain Rankine cycle with P-V, T-S & H-s diagram and determine thermal efficiency, Work done, work ratio, and specific steam Consumption.
- 2.4 Solve Simple Problems.
- 2.5. List of thermal power stations in the state with their capacities.
- 2.6 Boiler Accessories: Operation of Air pre heater, Operation of Economiser, Operation Electrostatic precipitator and Operation of super heater. Need of boiler mountings and operation of boiler
- 2.7 Draught systems (Natural draught, Forced draught & balanced draught) with their advantages & disadvantages.
- 2.8 Steam prime movers: Advantages & disadvantages of steam turbine, Elements of steam turbine, governing of steam turbine. Performance of steam turbine: Explain Thermal efficiency, Stage efficiency and Gross efficiency.
- 2.9 Steam condenser: Function of condenser, Classification of condenser. function of condenser auxiliaries such as hot well, condenser extraction pump, air extraction pump, and circulating pump.
- 2.10 Cooling Tower: Function and types of cooling tower, and spray ponds
- 2.11 Selection of site for thermal power stations.

3.0 NUCLEAR POWER STATIONS:

- 3.1 Classify nuclear fuel (Fissile & fertile material)
- 3.2 Explain fusion and fission reaction.
- 3.3 Explain working of nuclear power plants with block diagram .
- 3.4 Explain the working and construction of nuclear reactor .
- 3.5 Compare the nuclear and thermal plants.
- 3.6 Explain the disposal of nuclear waste.
- 3.7 Selection of site for nuclear power stations.
- 3.8 List of nuclear power stations.

4.0 DIESEL ELECTRIC POWER STATIONS:

- 4.1 State the advantages and disadvantages of diesel electric power stations.
- 4.2 Explain briefly different systems of diesel electric power stations: Fuel storage and fuel supply system, Fuel injection system, Air supply system, Exhaust system, cooling system, Lubrication system, starting system, governing system.
- 4.3 Selection of site for diesel electric power stations.
- 4.4 Performance and thermal efficiency of diesel electric power stations.

5.0 HYDEL POWER STATIONS:

- 5.1 State advantages and disadvantages of hydroelectric power plant.
- 5.2 Classify and explain the general arrangement of storage type hydroelectric project and explain its operation.
- 5.3 Selection of site of hydel power plant.
- 5.4 List of hydro power stations with their capacities and number of units in the state.
- 5.5 Types of turbines and generation used

5.6 Simple problems.

6.0 **GAS TURBINE POWER STATIONS**

6.1 Selection of site for gas turbine stations.

6.2 Fuels for gas turbine

6.3 Elements of simple gas turbine power plants

6.4 Merits, demerits and application of gas turbine power plants.



CHAPTER : 01

INTRODUCTION

Sources of Energy

Various sources of Energy are

- Fossil Fuel
- Energy stored in water
- Nuclear Energy
- Wind power
- Solar Energy
- Tidal Energy
- Geothermal Energy
- Thermo electric power

Fossil Fuel :

- A chemical fuel is a substance which releases heat energy on combustion. The main combustible element of any fuel are Carbon, Hydrogen and Sulphur.
- Coal is a solid fuel. Coal is classified into four types according to their quality that is Peat, Lignite, Bituminous and Anthracite.

Nuclear Fuel :

- It is that type of fuel which can produce a large amount of energy by utilizing a small amount of fuel.
- Nuclear fuel are Uranium, Thorium
- Complete fission of 1KG Uranium produces energy equivalent to 4500 tonnes of coal and 2000tonnes of Oil.

Solar Energy :

- It can be utilized in two ways, that is By Using the heat of solar energy and By Solar Cell
 - Glass lense and reflectors are used to concentrate the solar radiation on a boiler, which produces large amount of heat in the boiler to produce the steam.
 - In other way by using solar panel we can produce electric energy from solar energy.
-

Geothermal Energy :

- At some places on the earth surfaces, natural steam escape from the ground. The energy of such steam is called **Geothermal energy** or **terrestrials heat**.
- **Geothermal Energy** or Hot steam evolving from the earth can be directly utilized to produce work in turbine to generate power.
- Otherwise, the hot water or volcanic activity can be utilized to heat the water to produce the steam and this steam can be utilized to run the turbine to produce the power.

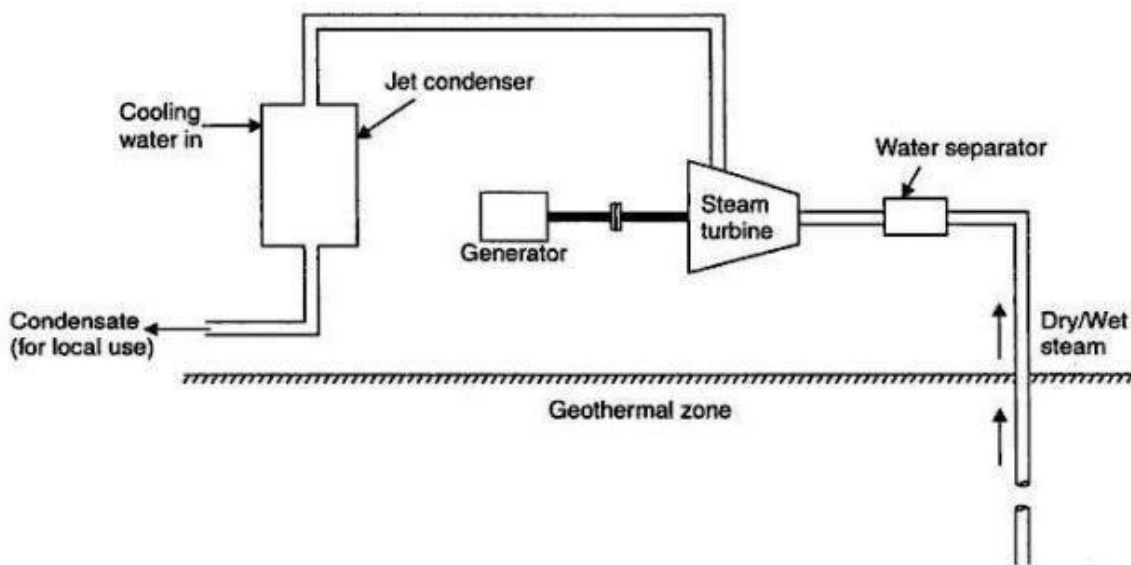

Tidal Power :

- The rise and fall of tides can be utilized to develop electric power.
 - On the mouth of the sea, a dam is created. A gate is there, which is opened at the time of high tide and water enters into the gate.
 - When the tides fall, the storage water is drained by using a low head turbine, which develops electricity.
 - Continuous power can be produced by using both way turbines.
-

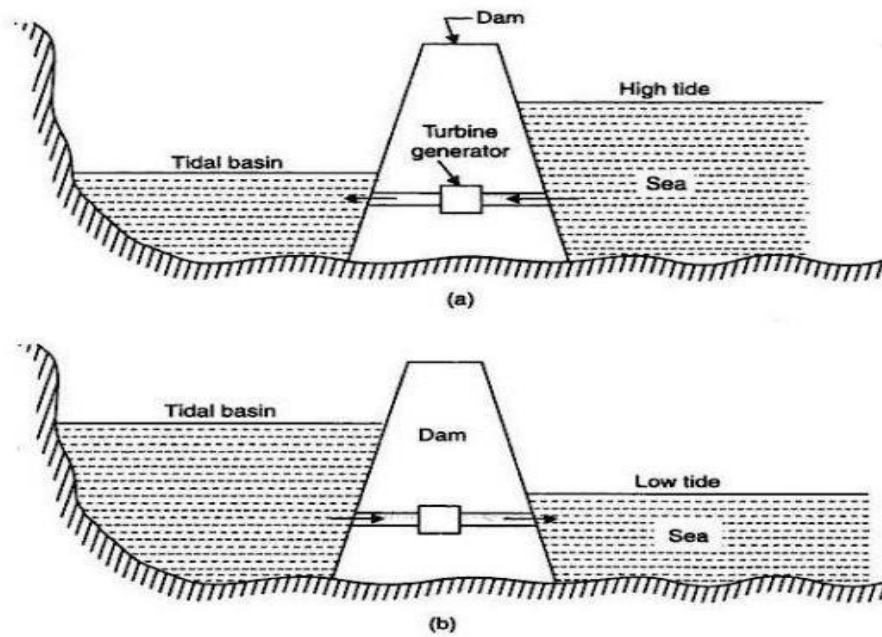

Fig. 1.1. Generation of power by tides.

Central and Captive Power Station

Captive Power station

- A captive power plant, also called autoproducer or embedded generation, is an electricity generation facility used and managed by an industrial or commercial energy user for their own energy consumption
- This type of power station is run by a manufacturing company for its own use and its out put is not available for generation.

Central Power Station :

- The power station which is designed to state the electricity for commercial pupose is called central power station.

Classification of power plant according to power :

Power plants are of five types

1. Steam power plant using coal
2. I.C. Engine power Station
3. Gas turbine power Station
4. Hydro Electric Power Station
5. Nuclear Power Station

Importance of Electrical Power in Day today Life

Electricity is one of the most important blessings that science has given to mankind. It has also become a part of modern life and one cannot think of a world without it. Electricity has many uses in our day to day life. It is used for lighting rooms, working fans and domestic appliances like using electric stoves, A/C and more. All these provide comfort to people. In factories, large machines are worked with the help of electricity. Essential items like food, cloth, paper and many other things are the product of electricity.

Overview of method of electrical power generation

There are various methods of electricity generation dependent on types of energy.

Among resource energies, coal and natural gas are used to generate electricity by combustion (thermal power), Uranium by nuclear fission (nuclear power), to utilize their heat for boiling water and rotating steam turbine.

Among renewable energies, sunlight is directly converted into electricity (photovoltaics), rotation energy by wind is converted into electricity (wind power), rotating water wheel by running water to generate(hydro). Magmatic heat boils underground water to rotate steam turbine to generate (geothermal).

Continuous technology development for them are proceeding to convert resource energies or renewable energies into electricity with less loss. It is also important for the operation of power plant to do maintenance or training of operators.

IMPORTANT QUESTIONS

- 1. What are the various sourc/es of energy?**
 - 2. What is geothermal energy ?**
 - 3. What is Tidal power?**
 - 4. What is Teritrial heat?**
 - 5. Define central power station and Captive power station?**
 - 6. What are use of electrical energy in day to day life?**
-

Chapter – 02

THERMAL POWER STATION

A steam power plant converts the chemical energy of the fossil fuel into mechanical or electrical energy. It is achieved by raising the steam in the boiler, expanding it through the turbines and coupling the turbines to the generators which converts mechanical energy to the electrical energy.

Layout of steam power stations:

A modern steam power plant consists of

1. Coal and ash circuit
2. Air and Gas circuit
3. Feed water and steam flow circuit
4. Cooling water circuit

Coal and Ash Circuit:

- Coal arrives at the storage yard and after necessary handling, passes to the furnace through the fuel feeding device
- Ash resulting from the combustion of coal collected at the bottom of the boiler and is removed to the ash storage yard through the handling equipment

Air and Gas Circuit

- Air is taken in from atmosphere through the action of a forced or induced draught fan and passes onto the furnace through the air preheater. Where it has been heated by the heat of flue gases which passes to the chimney via the pre heater.
- The flue gases after passing around boiler tubes and super heater tubes in the furnace first pass through the a dust catching device or precipitator than through the economizer and finally through the air pre heater before being exhausted to the atmosphere

Feed water and steam flow circuit

- In the water and steam circuit condensate leaking the condenser is first heated in a closed feed water heater through extracted steam from the lowest pressure extraction point of turbine. It then passes through the deaerator and few more water heater before going into the boiler through economizer.
 - In the boiler drum and tubes, water circulates due to the difference between the density of water in the lower temp and higher temp section of boiler. Wet steam from the drum is heated up in the super heater before being supplied to the turbine.
-

- After expanding, in the turbine, the steam is again circulated through the reheater to gain the original dryness. After that it is finally entered into the condenser for condensation.

Cooling water Circuit:

- Cooling water supply to the condenser helps in maintaining a low pressure on it. Water is circulated from river, lake or sea for cooling.
- In some cases cooling pond (Spray pond) is there to recirculate the same water.

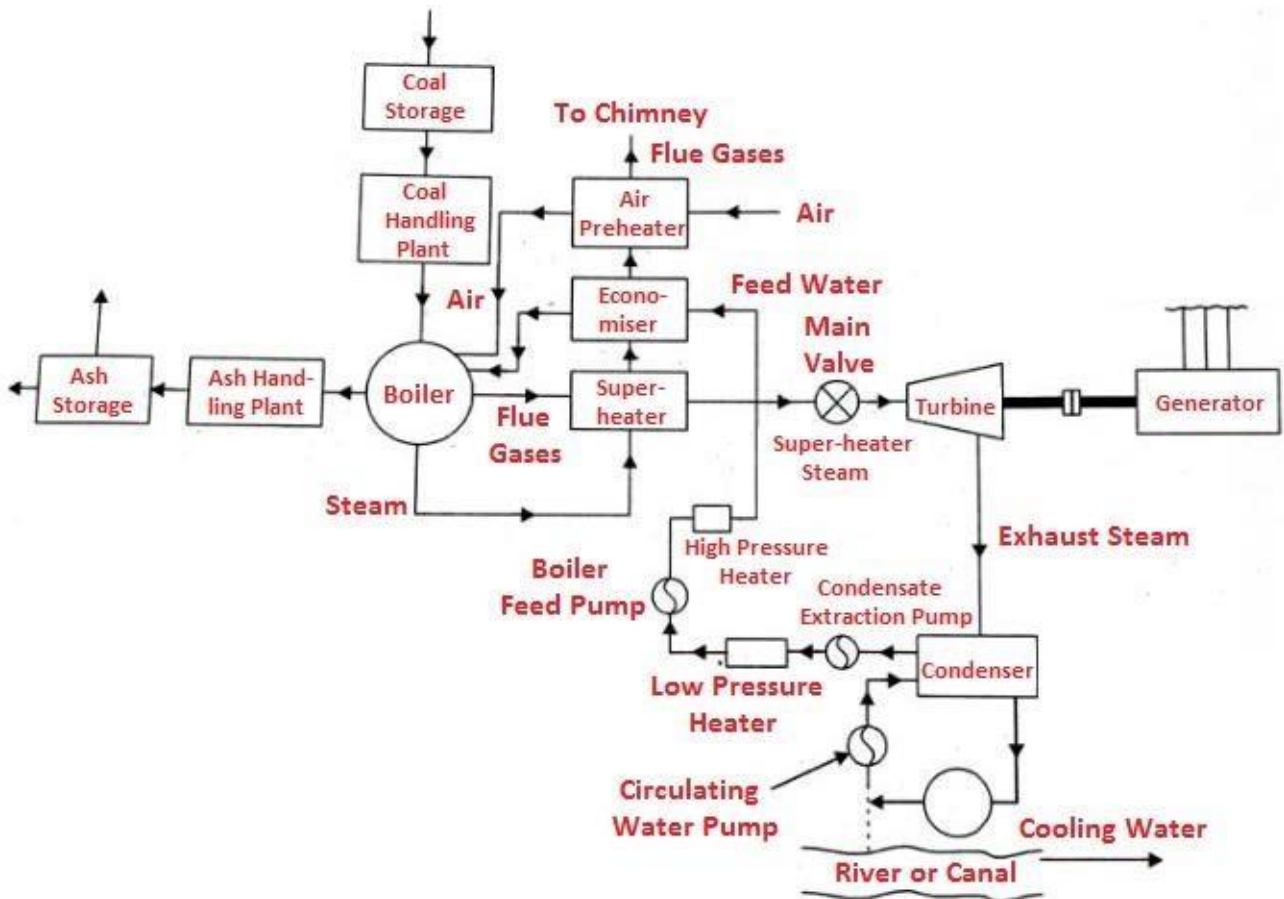

Layout of a Thermal Power Plant

Steam Power Cycle :

A thermodynamic cycle in which water is heated in a boiler, then converted into steam, then allowed to expand in a turbine which produces mechanical energy to drive the generator is known as steam power cycle.

Carnot Cycle :

Carnot cycle on T-s and P-V diagram is shown in figure. It consists of two constant pressure process operation (4-1) and (2-3) and two frictionless adiabatics (1-2) and (3-4).

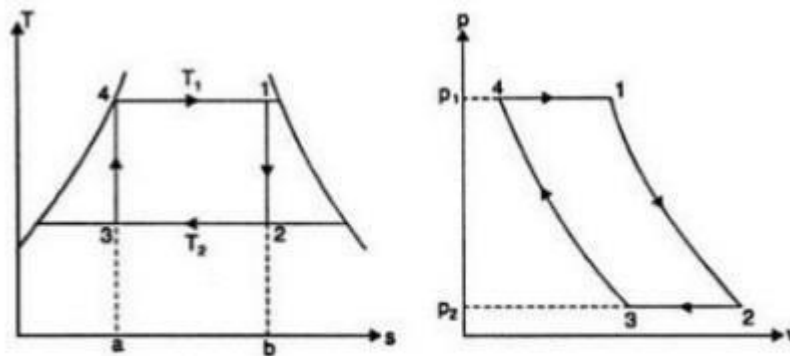

Carnot cycle on T-s and p-v diagrams.

- 1. Operation (4-1) :** 1 kg of boiling water at temperature T_1 is heated to form wet steam of dryness fraction X_1 . Thus heat is absorbed at constant temp. T_1 and pressure P_1 during this operation.
- 2. Operation (1-2) :** During this operation steam is expanded isentropically to temp. T_2 and pressure P_2 . The point 2 represents the condition of steam after expansion.
- 3. Operation (2-3) :** During this operation heat is rejected at constant pressure P_2 and temp. T_2 . As the steam is exhausted it becomes wetter and cooled from 2 to 3.
- 4. Operation (3-4) :** During this operation the wet steam at '3' is compressed isentropically till the steam regains its original state of temp T_1 and pressure P_1 . Thus cycle is completed.

Heat supplied at constant temperature T_1 [Operation (4-1)] = Area 4-1-b-1 = $T_1 (s_1 - s_4)$ or $T_1 (s_2 = s_3)$.

Heat rejected at constant temperature T_2 (Operation 2-3) = Area 2-3-a-b = $T_2 (s_2 = s_3)$.

Since there is no exchanging of heat during isentropic operation (1-2) and (3-4),

Net work done = Heat supplied – Heat rejected

$$= T_1 (s_2 = s_3) - T_2 (s_2 = s_3)$$

$$= (T_1 - T_2) (s_2 = s_3)$$

$$\begin{aligned} \text{Carnot cycle efficiency } \eta &= \frac{\text{Workdone}}{\text{Heat Supplied}} \\ &= \frac{(T_1 - T_2) (s_2 = s_3)}{T_1 (s_2 = s_3)} \\ &= \frac{T_1 - T_2}{T_1} \end{aligned}$$

$$\text{Carnot cycle efficiency } \eta = \frac{T_1 - T_2}{T_1}$$

Rankine Cycle :

- Rankine cycle is the theoretical cycle in which the steam turbines works.
- Rankine cycle consists of two constant pressure process and two Reversible adiabatic (Isentropic) process.

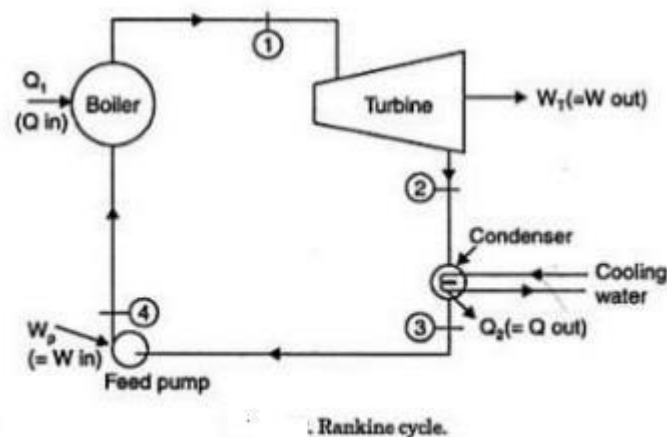

Process

1-2 : Reversible adiabatic (isentropic) expansion in turbine

2-3 : Constant pressure heat rejection in condenser

3-4 : Reversible adiabatic compression in

feed pump

4-1 : Constant pressure heat addition in the boiler

Let us consider that 1 Kg of steam is flowing in the cycle.



Applying steady flow energy equation to boiler, turbine, condenser and pump.

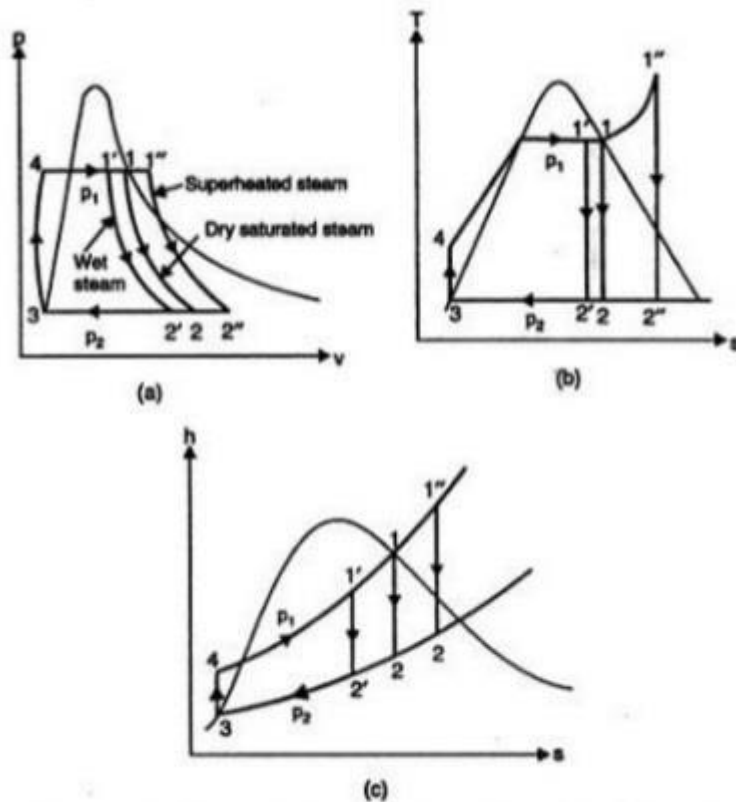

(a) p - v diagram ; (b) T - s diagram ; (c) h - s diagram for Rankine cycle.

For Boiler :

$$h_{f4} + Q_1 = h_1$$

$$\Rightarrow Q_1 = h_1 - h_{f4} \text{ (Heat added)}$$

For Turbine :

$$h_1 = W_T + h_2$$

$$\Rightarrow W_T = h_1 - h_2 \text{ (Turbine work)}$$

For condenser :

$$h_2 = Q_2 + h_{f3}$$

$$\Rightarrow Q_2 = h_2 - h_{f3} \text{ (Heat rejected)}$$

For feed Pump :

$$h_{f3} + W_p = h_{f4}$$

$$\Rightarrow W_p = h_{f4} - h_{f3} \text{ (Pump Work)}$$

Now efficiency of Rankine cycle

$$\eta_{\text{Rankine}} = \frac{W_{\text{net}}}{Q_1} = \frac{W_T - W_p}{Q_1} = \frac{(h_1 - h_2) - (h_{f4} - h_{f3})}{h_1 - h_{f4}}$$

$$\eta_{\text{Rankine}} = \frac{(h_1 - h_2) - (h_{f4} - h_{f3})}{h_1 - h_{f4}}$$

The feed pump handles liquid water which is incompressible, this means with the increase in pressure its density or specific volume undergoes a little change.

Using general property relation for reversible adiabatic compression

$$Tds = dh - vdp$$

$$ds = 0$$

$$dh = vdp$$

$$\text{or } \Delta h = v \Delta p$$

$$\text{or } h_{f4} - h_{f3} = v_3 (P_1 - P_2)$$

When P is in bar and V is in m³/Kg

$$h_{f4} - h_{f3} = v_3 (P_1 - P_2) \times 10^5 \text{ J/Kg}$$

The feed pump term ($h_{f4} - h_{f3}$) beign a small quantity in comparision with turbine work W_T , So it is neglected specially when the boiler pressure are low.

So ,

$$\text{Rankine efficiency , } \eta_{\text{Rankine}} = \frac{(h_1 - h_2)}{h_1 - h_{f4}}$$

Work done :

The total work put when the steam is go through a complete cycle is known as work done by the cycle

Steam Rate :

The steam rate is defined as the rate of steam flow(Kg/H) required to produce units shaft output (1KW)

$$\text{Steam Rate} = \frac{3600}{W_t - W_p} \text{ Kg/Kwh}$$

- Steam rate is used to measure the capacity of a steam power plant
- If pump work is neglected, then

$$\text{Steam rate} = \frac{3600}{W_t} \text{ Kg/Kwh} = \frac{3600}{h_1 - h_2} \text{ Kg/Kwh}$$

Heat Rate :

The cycle efficiency is also expressed as heat rate, it is defined as the rate of heat input required to produce unit work output (1KW)

$$\text{Heat rate} = \frac{3600Q_1}{W_t - W_p} \text{ Kg/Kwh} = \frac{3600}{\eta_{cycle}} \text{ Kg/Kwh}$$

Work Ratio:

Work ratio is defined as the ratio between network output to the work done by the turbine in a power plant cycle. it is a dimensionless number expressed in percentage.

$$\text{Work ratio} = \frac{W_{net}}{W_t} \text{ Kg/Kwh} = \frac{W_t - W_p}{W_t} \text{ Kg/Kwh}$$

Solve simple Example

Example A steam turbine receives steam at 15 bar and 350°C and exhausts to the condenser at 0.06 bar. Determine the thermal efficiency of the ideal Rankine cycle operating between these two limits.

Solution. Pressure of steam at the entry to the steam turbine,

$$p_1 = 15 \text{ bar}, 350^\circ\text{C}$$

Condenser pressure,

$$p_2 = 0.06 \text{ bar}$$

Rankine efficiency :

From steam tables,

$$\text{At 15 bar, } 350^\circ\text{C} \quad : \quad h = 3147.5 \text{ kJ/kg}, \quad s = 7.102 \text{ kJ/kg K}$$

$$\text{At 0.06 bar} \quad : \quad h_f = 151.5 \text{ kJ/kg}, \quad h_{fg} = 2415.9 \text{ kJ/kg}$$

$$s_f = 0.521 \text{ kJ/kg K}, \quad s_{fg} = 7.809 \text{ kJ/kg K}$$

Since the steam in the turbine expands isentropically,

$$s_1 = s_2 = s_f + x_2 s_{fg2}$$

$$7.102 = 0.521 + x_2 \times 7.809$$

$$\therefore \quad x_2 = \frac{7.102 - 0.521}{7.809} = 0.843$$

$$h_1 = 3147.5 \text{ kJ/kg},$$

$$h_2 = h_f + x_2 h_{fg2} = 151.5 + 0.843 \times 2415.9 = 2188.1 \text{ kJ/kg}$$

$$\therefore \quad \eta_{\text{Rankine}} = \frac{h_1 - h_2}{h_1 - h_f} \text{ (neglecting pump work)}$$

$$= \frac{3147.5 - 2188.1}{3147.5 - 151.5} = 0.32 \text{ or } 32\%. \text{ (Ans.)}$$

Example In a steam turbine steam at 20 bar, 360°C is expanded to 0.08 bar. It then enters a condenser, where it is condensed to saturated liquid water. The pump feeds back the water into the boiler. Assume ideal processes, find per kg of steam the net work and the cycle efficiency.

Solution. Boiler pressure, $p_1 = 20 \text{ bar (} 360^\circ\text{C)}$

Condenser pressure, $p_2 = 0.08 \text{ bar}$

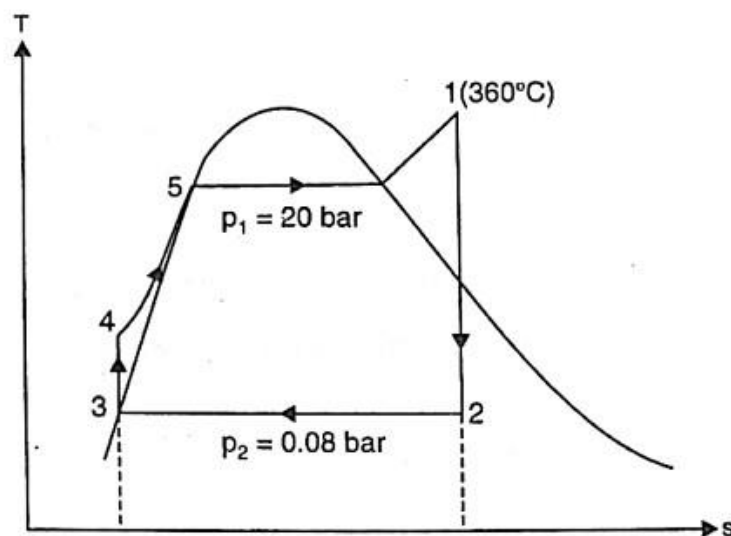

From steam tables,

At 20 bar (p_1), 360°C :
 $h_1 = 3159.3 \text{ kJ/kg}$
 $s_1 = 6.9917 \text{ kJ/kg-K}$

At 0.08 bar (p_2) :
 $h_3 = h_{f(p_2)} = 173.88 \text{ kJ/kg}$,
 $s_3 = s_{f(p_2)} = 0.5926 \text{ kJ/kg K}$

$$h_{fg(p_2)} = 2403.1 \text{ kJ/kg}, \quad s_{g(p_2)} = 8.2287 \text{ kJ/kg K}$$

$$v_{f(p_2)} = 0.001008 \text{ m}^3/\text{kg} \quad \therefore \quad s_{fg(p_2)} = 7.6361 \text{ kJ/kg K}$$

Now

$$s_1 = s_2$$

$$6.9917 = s_{f(p_2)} + x_2 s_{fg(p_2)} = 0.5926 + x_2 \times 7.6361$$

$$\therefore \quad x_2 = \frac{6.9917 - 0.5926}{7.6361} = 0.838$$

$$\therefore \quad h_2 = h_{f(p_2)} + x_2 h_{fg(p_2)} \\ = 173.88 + 0.838 \times 2403.1 = 2187.68 \text{ kJ/kg.}$$

Net work, W_{net} :

$$W_{\text{net}} = W_{\text{turbine}} - W_{\text{pump}}$$

$$W_{\text{pump}} = h_{f_4} - h_{f(p_2)} (= h_{f_3}) = v_{f(p_2)} (p_1 - p_2) \\ = 0.00108 \text{ (m}^3/\text{kg)} \times (20 - 0.08) \times 100 \text{ kN/m}^2 \\ = 2.008 \text{ kJ/kg}$$

$$\text{[and } h_{f_4} = 2.008 + h_{f(p_2)} = 2.008 + 173.88 = 175.89 \text{ kJ/kg]}$$

$$W_{\text{turbine}} = h_1 - h_2 = 3153.9 - 2187.68 = 971.62 \text{ kJ/kg}$$

$$W_{\text{net}} = 971.62 - 2.008 = \mathbf{969.61 \text{ kJ/kg. (Ans.)}}$$

$$Q_1 = h_1 - h_{f_4} = 3159.3 - 175.89 = 2983.41 \text{ kJ/Kg}$$

$$\eta_{\text{cycle}} = \frac{W_{\text{net}}}{Q_1} = \frac{969.61}{2983.41} = \mathbf{0.325 \text{ or } 32.5\%}$$

Example 2.4. A simple Rankine cycle works between pressures 28 bar and 0.06 bar, the initial condition of steam being dry saturated. Calculate the cycle efficiency, work ratio and specific steam consumption.

Solution.

From steam tables,

At 28 bar : $h_1 = 2802 \text{ kJ/kg}$, $s_1 = 6.2104 \text{ kJ/kg K}$

At 0.06 bar : $h_{f_2} = h_{f_3} = 151.5 \text{ kJ/kg}$, $h_{fg_2} = 2415.9 \text{ kJ/kg}$,

$$s_{f_2} = 0.521 \text{ kJ/kg K}, \quad s_{fg_2} = 7.809 \text{ kJ/kg K}$$

$$v_f = 0.001 \text{ m}^3/\text{kg}$$

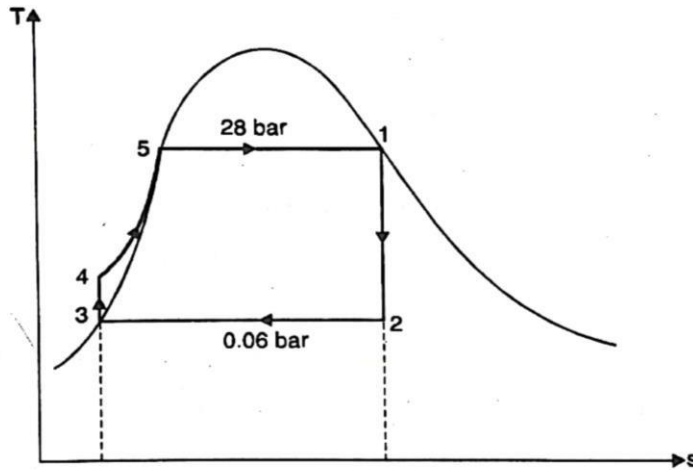

Fig. 2.8

Considering turbine process 1-2, we have :

$$s_1 = s_2$$

$$6.2104 = s_{f_2} + x_2 s_{fg_2} = 0.521 + x_2 \times 7.809$$

$$\therefore x_2 = \frac{6.2104 - 0.521}{7.809} = 0.728$$

$$\therefore h_2 = h_{f_2} + x_2 h_{fg_2} = 151.5 + 0.728 \times 2415.9 = 1910.27 \text{ kJ/kg}$$

$$\therefore \text{Turbine work, } W_{\text{turbine}} = h_1 - h_2 = 2802 - 1910.27 = 891.73 \text{ kJ/kg}$$

$$\text{Pump work, } W_{\text{pump}} = h_{f_4} - h_{f_3} = v_f (p_1 - p_2)$$

$$= \frac{0.001(28 - 0.06) \times 10^5}{1000} = 2.79 \text{ kJ/kg}$$

$$[\because h_{f_4} = h_{f_3} + 2.79 = 151.5 + 2.79 = 154.29 \text{ kJ/kg}]$$

$$\therefore \text{Net work, } W_{\text{net}} = W_{\text{turbine}} - W_{\text{pump}}$$

$$= 891.73 - 2.79 = 888.94 \text{ kJ/kg}$$

$$\text{Cycle efficiency} = \frac{W_{\text{net}}}{Q_1} = \frac{888.94}{h_1 - h_{f_4}}$$

$$= \frac{888.94}{2802 - 154.29} = 0.3357 \text{ or } 33.57\%. \text{ (Ans.)}$$

$$\text{Work ratio} = \frac{W_{\text{net}}}{W_{\text{turbine}}} = \frac{888.94}{891.73} = 0.997. \text{ (Ans.)}$$

$$\text{Specific steam consumption} = \frac{3600}{W_{\text{net}}} = \frac{3600}{888.94} = 4.049 \text{ kg/kWh. (Ans.)}$$

Example 2.5. In a Rankine cycle, the steam at inlet to turbine is saturated at a pressure of 35 bar and the exhaust pressure is 0.2 bar. Determine :

- (i) The pump work (ii) The turbine work
 (iii) The Rankine efficiency (iv) The condenser heat flow
 (v) The dryness at the end of expansion.

Assume flow rate of 9.5 kg/s.

Solution. Pressure and condition of steam, at inlet to the turbine,

$$p_1 = 35 \text{ bar, } x = 1$$

$$\text{Exhaust pressure, } p_2 = 0.2 \text{ bar}$$

$$\text{Flow rate, } \dot{m} = 9.5 \text{ kg/s}$$

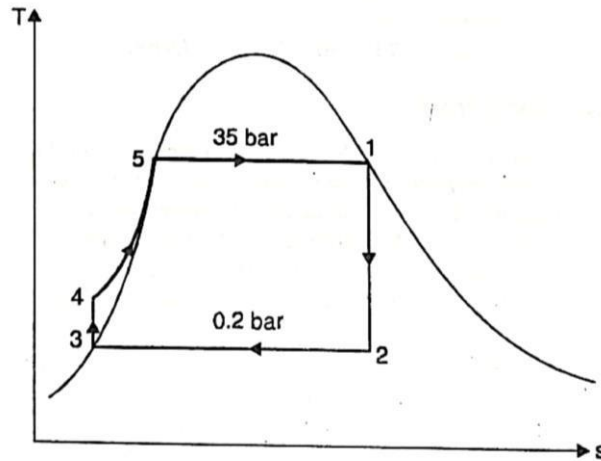

Fig. 2.9

From steam tables :

At 35 bar :

$$h_1 = h_{g1} = 2802 \text{ kJ/kg}, \quad s_{g1} = 6.1228 \text{ kJ/kg K}$$

At 0.26 bar :

$$h_f = 251.5 \text{ kJ/kg}, \quad h_{fg} = 2358.4 \text{ kJ/kg},$$

$$v_f = 0.001017 \text{ m}^3/\text{kg}, \quad s_f = 0.8321 \text{ kJ/kg K}, \quad s_{fg} = 7.0773 \text{ kJ/kg K}.$$

(i) The pump work :

Pump work

$$= (p_4 - p_3) v_f = (35 - 0.2) \times 10^5 \times 0.001017 \text{ J}$$

or 3.54 kJ/kg

$$\left[\begin{array}{l} \text{Also } h_{f4} - h_{f3} = \text{Pump work} = 3.54 \text{ kJ/kg} \\ \therefore h_{f4} = 251.5 + 3.54 = 255.04 \text{ kJ/kg} \end{array} \right]$$

Now power required to drive the pump

$$= 9.5 \times 3.54 \text{ kJ/s} \quad \text{or} \quad 33.63 \text{ kW. (Ans.)}$$

(ii) The turbine work :

$$s_1 = s_2 = s_{f2} + x_2 \times s_{fg2}$$

$$6.1228 = 0.8321 + x_2 \times 7.0773$$

$$\therefore x_2 = \frac{6.1228 - 0.8321}{7.0773} = 0.747$$

$$\therefore h_2 = h_{f2} + x_2 h_{fg2} = 251.5 + 0.747 \times 2358.4 = 2013 \text{ kJ/kg}$$

$$\therefore \text{Turbine work} = \dot{m} (h_1 - h_2) = 9.5 (2802 - 2013) = 7495.5 \text{ kW. (Ans.)}$$

It may be noted that pump work (33.63 kW) is very small as compared to the turbine work (7495.5 kW).

(iii) The Rankine efficiency :

$$\eta_{\text{Rankine}} = \frac{h_1 - h_2}{h_1 - h_{f2}} = \frac{2802 - 2013}{2802 - 251.5} = \frac{789}{2550.5} = 0.3093 \text{ or } 30.93\%. \quad (\text{Ans.})$$

(iv) The condenser heat flow :

$$\text{The condenser heat flow} = \dot{m} (h_2 - h_{f3}) = 9.5 (2013 - 251.5) = 16734.25 \text{ kW. (Ans.)}$$

(v) The dryness at the end of expansion :

The dryness at the end of expansion,

$$x_2 = 0.747 \quad \text{or} \quad 74.7\%. \quad (\text{Ans.})$$

List of thermal power station in the state with their capacities

- Thermal power is the biggest source of power in India.
- More than 70% of total energy consumed in India is shared by thermal power.
- Following are the major Thermal Power Plants (producing more than 1,500 MW) in India –

Name of the Plant	Location	Capacity
Mundra Thermal Power Station	Gujarat	4,620 MW
Vindhyachal Thermal Power Station	Madhya Pradesh	4,260 MW
Mundra Ultra Mega Power Plant	Gujarat	4,150 MW
KSK Mahanadi Power Project	Chhattisgarh	3,600 MW
Jindal Tamnar Thermal Power Plant	Chhattisgarh	3,400 MW
Tiroda Thermal Power Station	Maharashtra	3,300 MW
Barh Super Thermal Power Station	Bihar	3,300 MW
Talcher Super Thermal Power Station	Odisha	3,000 MW
Sipat Thermal Power Plant	Chhattisgarh	2,980 MW

Boiler Accessories :

Operation of Air pre heater :

- ➔ The function of the air preheater is to increase the temperature of the air before it enters the furnace.
 - ➔ It is placed after the economiser so the flue gases pass through the economiser and then to the air preheater.
 - ➔ Air preheater consists of plates or tubes with hot gases on one side and fresh air on the other side.
-

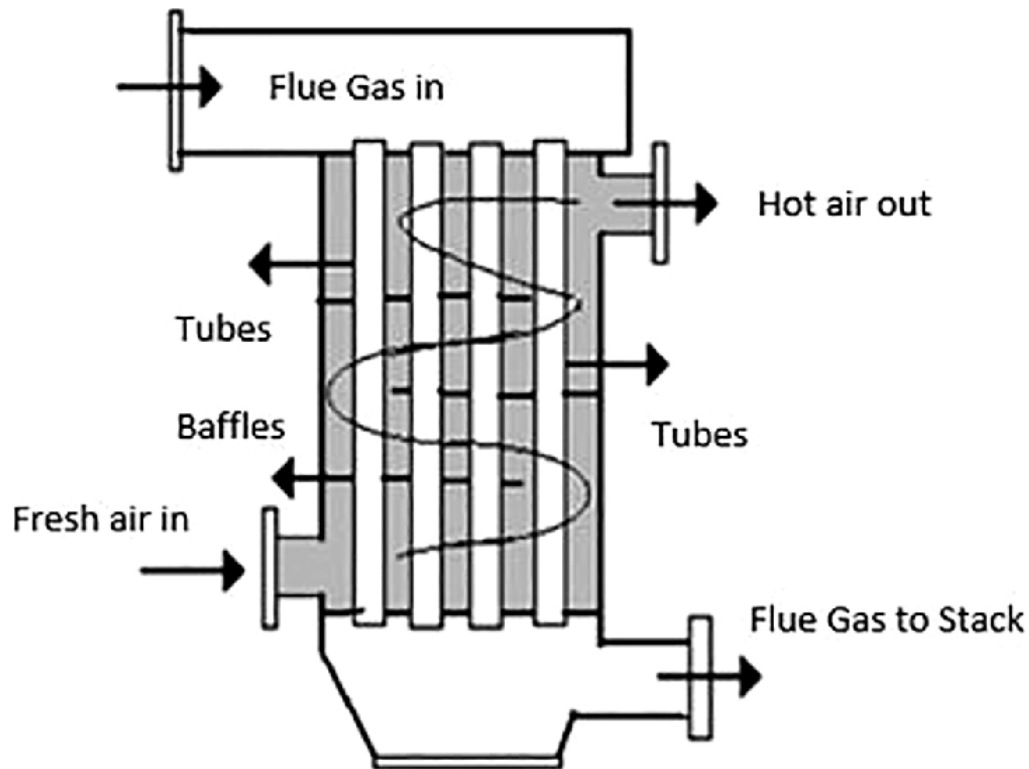

Advantages :

- It heat the air before entering into the furnance, so it helps in complete burning of the fuel.
- It increases the efficiency of the plant

Operation of Economiser :

- Economics is a device in which the waste heat of the flue gases is utilised for heating the feedwater. Economiser are of twoTypes
 1. Integral type
 2. Independent type
- If the economy is not an integral part of the boiler then it is independent type.
- If the economy is connected to the boil then it is called integral type economiser.

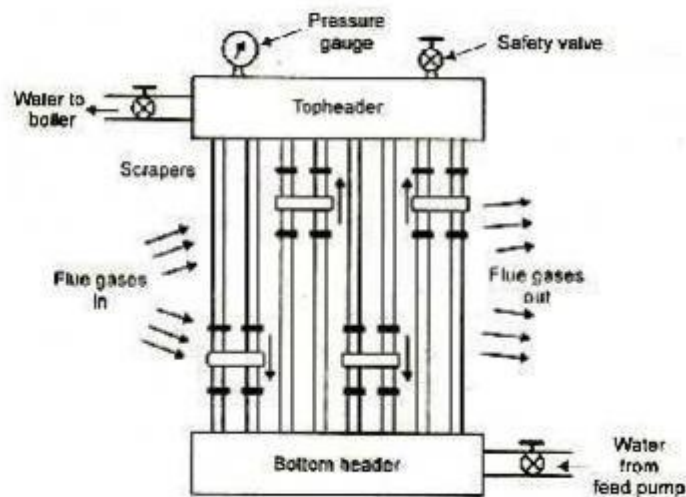

Fig. Economizer

➔ Economiser is a tubular structure in which hot flue gases move in opposite direction to the feed water so the feed water is heated before entering into the boiler

Advantages :

1. Temp range between various parts of the boiler is reduced which results in reduction of stress due to unequal
2. Evaporation capacity of boiler increases.
3. Overall efficiency of the plant increases.

Operation of Super Heater:

The function of a superheater is to increase the temperature of the steam above its saturation point. Superheater are located in the path of the furnace so that heat is recovered by the superheater from the hot gases.

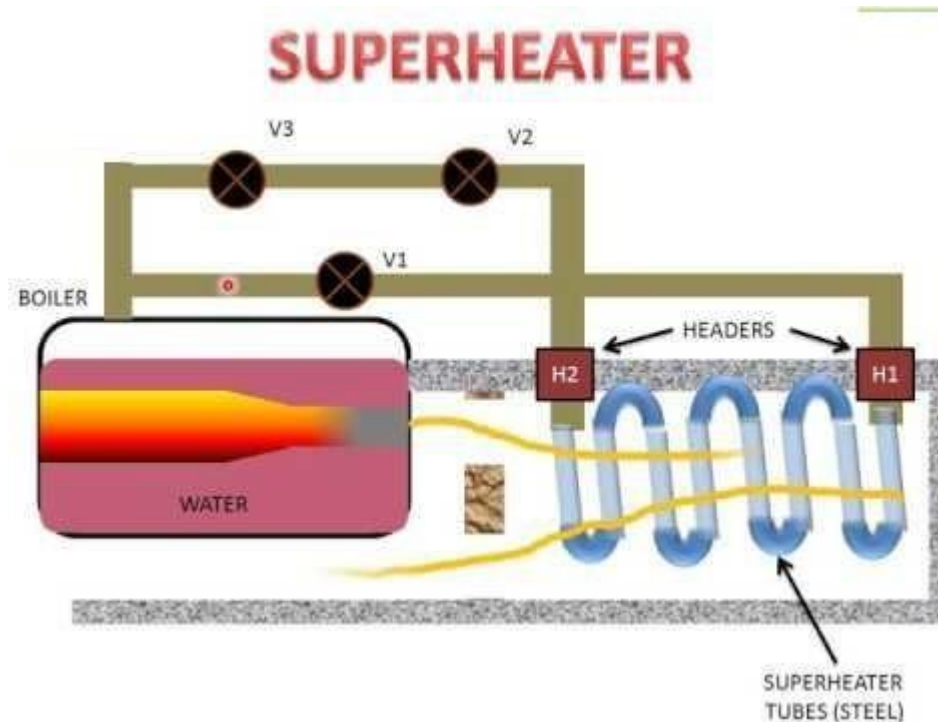

Electrostatic Precipitator (ESP):

An electrostatic precipitator (ESP) removes particles from a gas stream by using electrical energy to charge particles either positively or negatively. The energized electrodes create ions that collide with the particles and apply the electrical charge to the particles contained in the incoming gas stream.

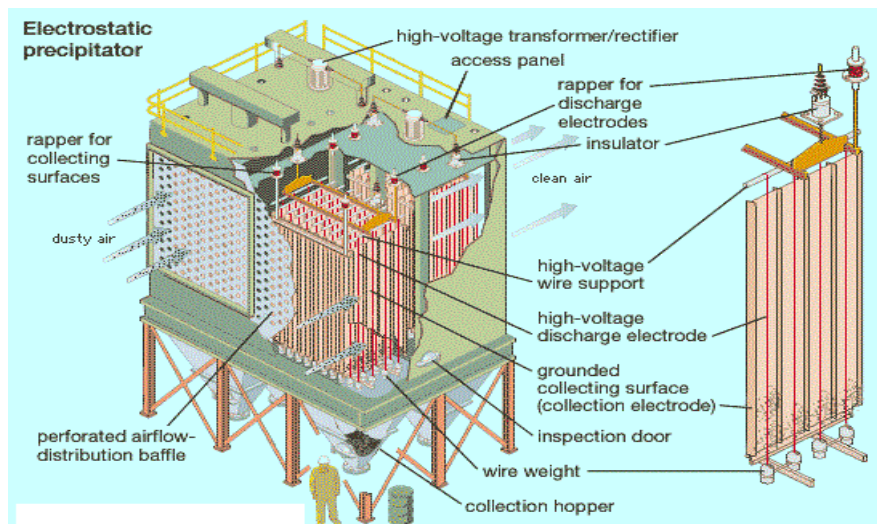

- ➔ Particulate Collection Device used in industries to minimize air pollution
Efficiency of 99% in many industries
- ➔ Can handle large gas volumes with a wide range of inlet temperatures, pressures, dust volumes, and acid gas conditions

- Can collect particles of varying sizes in dry and wet states

Need of Boiler Mountings :

- Boiler mountings are a set of safety device installed for the safe operation of a boiler. There are seven main mountings on a boiler shell; safety valve, steam stop valve, vent valve, pressure gauge, water level indicator, feed check valve and fusible plug.
- These equipment save the boiler from damage due to extreme pressure, steam back flow, shell collapse due to vacuum, unregulated steam pressure, low water level, back flow of feed water to the pump and dry running respectively.

Operation of Boilers :

- A boiler is a closed vessel used to boil water to produce saturated or superheated steam. Also known as steam generator, they use heat energy from exhaust or furnace to produce steam. A boiler can produce steam under pressure and vacuum condition; from distilled / feed water for steam power plant and marine application on ship.
- On board ship, boiler is used to generate steam for; propulsion (steam ship), power generation, shoot blowing, auxiliaries (steam ship), fresh water generator, cargo heating, running steam driven pumps, steam ejectors and running cargo pump turbine. Air is supplied to the boiler furnace to produce heat energy.
- This heat energy is then supplied to the water; through the large surface area between water and boiler furnace. Steam produced is then collected separately in the steam drum for further usage. The boiler is a closed vessel where water is boiled off the heat received from the furnace.

Draught System :

- The small pressure difference which casues a flow of gas to take place is termed as a draught.
 - The function of the draught, in case of a boiler is to force air to the fire and to carry away the gaseous products of combustion.
-

Classification of Draught:

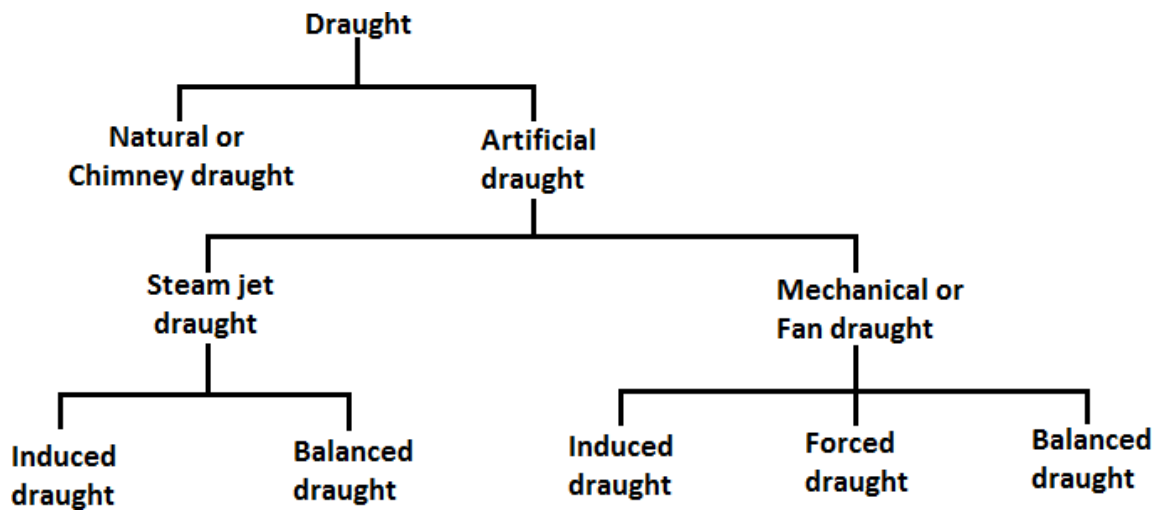

Natural draught:

- Natural draught is obtained by the use of a chimney.
- It produces the draught where, the air and gases are forced through the fuel bed, furnace, boiler passing the setting.
- The draught produced by the chimney is due to the density difference between the column of hot gases inside the chimney and the cold air inside.

Steam jet Draught:

- It employs steam to produce the draught

Mechanical draught

- Mechanical draught is produced by fans. There are two types of fans in use today. Forced draught (FD) and induced draught (ID) fans. When either one is used alone, it should overcome the total air and gas pressure losses within the steam generator.

Induced draught

- Induced draught fans are normally located at the foot of the stack. They handle hot combustion gases. Their power requirements are, more than forced draught fans. They must cope with corrosive combustion products and fly ash. Induced draught fans are seldom placed alone.
-

Forced draught

- ➔ The forced draught fans are installed at inlet to the air preheater. They handle cold air. So they have less maintenance problems, consumes less power, and therefore, their capital and operating costs are low.

Balanced draught :

When both forced and induced draught fans are used in steam generator, the FN fans push atmospheric air into the furnace and the ID fans suck out the flue gases through the heat transfer surfaces into the stack. The stack because of its height, adds a natural driving pressure of its own. In such a case the furnace is said to operate with balanced draught.

The purpose of draught is as follows:

- i) To supply required amount of air to the furnace for the combustion of fuel. The amount of fuel that can be burnt per square root of grate area depends upon the quantity of air circulated through fuel bed.
- ii) To remove the gaseous products of combustion.

Steam Prime Movers:

The **prime mover** convert the natural resources of energy into power or electricity. The **prime movers** to be used for generating electricity could be diesel engine, **steam** engine, **steam** turbines, gas turbines, and water turbine.

Advantages and Disadvantages of steam turbines :

Advantages

- Since the steam turbine is a rotary heat engine, it is particularly suited to be used to drive an electrical generator.
 - Thermal efficiency of a steam turbine is usually higher than that of a reciprocating engine.
 - Very high power-to-weight ratio, compared to reciprocating engines.
 - Fewer moving parts than reciprocating engines.
 - Steam turbines are suitable for large thermal power plants. They are made in a variety of sizes up to 1.5 GW (2,000,000 hp) turbines used to generate electricity.
-

- In general, steam contains high amount of enthalpy (especially in the form of heat of vaporization). This implies lower mass flow rates compared to gas turbines.
- In general, turbine moves in one direction only, with far less vibration than a reciprocating engine.
- Steam turbines have greater reliability, particularly in applications where sustained high power output is required.

Disadvantages

- Although approximately 90% of all electricity generation in the world is by use of steam turbines, they have also some disadvantages.
- Relatively high overnight cost.
- Steam turbines are less efficient than reciprocating engines at part load operation.
- They have longer startup than gas turbines and surely than reciprocating engines.
- Less responsive to changes in power demand compared with gas turbines and with reciprocating engines.

Elements of steam turbines

1. Rotor
2. Stem chest
3. Casing
4. Governor system

Rotor

- Consists of shaft and disk assemblies with buckets. The shaft extends beyond the casing through the bearing cases. One end of the shaft is used for coupling to the driven pump. The other end of the shaft serves the speed governor and the over speed trip system.

Steam chest and the casing

- Connected to higher pressure steam supply line and the low pressure steam exhaust line respectively. The steam chest connected to casing, houses the governor valve and the over speed trip valve. The casing contains the rotor
-

and nozzles through which the steam is expanded and directed against the rotating buckets.

Casing sealing glands

- Seal the casing and the shaft. Spring backed segmental carbon rings used for this and supplemented by a spring backed labyrinth section for higher exhaust-steam.

The bearing cases

- Supports the rotor and assemble casing and steam chest. The bearing cases contain the journal bearings and the rotating oil seals, which prevent outward oil leakage and the entrance of water, dust, and steam.

The steam end bearing case contains the rotor positioning bearing and the rotating components of the over speed trip system. An extension of the steam end bearing housing enclose the rotating components of the speed – governor system.

Governor system

- Governor systems are speed-sensitive control systems that are integral with the steam turbine. The turbine speed is controlled by varying the steam flow through the turbine by positioning the governor valve. Consists of spring-opposed rotating weights, a steam valve, and an interconnecting linkage or servo motor system. The governor sense turbine shaft speed through direct connection, worm/worm wheel, or magnetic impulse from a gear.
- The turbine speed is compared to some predetermined set point and the governor output signal to a servo motor. Change in the turbine inlet and exhaust-steam conditions, and the power required by the pump will cause the turbine speed to change. The change in speed results in repositioning the governor weights and subsequent repositioning of the governor valve.

Steam Turbine Governing and Control :

- Steam turbine governing system is a method, used to maintain a constant steady speed of turbine.
 - The importance of this method is, the turbine can maintain a constant steady speed irrespective of variation of its load.
-

- A turbine governor is provided for this arrangement. The purpose of the governor is to supply steam into the turbine in such a way that the turbine gives a constant speed as far as possible under varying the load.
- So, basically Steam turbine governing system is a process where turbine maintains a steady output speed irrespective of variation of load. The different types of steam turbine governor of are:
- The principal methods of steam turbine governing are as follows :
 1. Throttle governing
 2. Nozzle governing
 3. By-pass governing
 4. Combination of 1 and 2 and 1 and 3.

1. Throttle Governing Of Steam Turbine:-

- Throttle Governing of steam Turbine is most popular and easiest way to control the turbine speed. When steam turbine controls its output speed by varying the quantity of steam entering the turbine is called Throttle Governing. It is also known as Servomotor methods.
 - In this system, a centrifugal governor is driven from the main shaft of turbine by belt or gear arrangement.
 - A control valve is used to control the direction of oil flow which supplied by the pipe AA or BB.
 - The servomotor or relay valve has a piston which moves towards left or right depending upon the pressure of oil flow through the pipes AA or BB.
 - This cylinder has connected a needle which moves inside the nozzle.
 - When the turbine is running at normal speed, everything in the turbine such as such control valve, servomotor, piston position, fly balls of centrifugal governor will be in their normal position as shown in the figure.
 - The mouth of both pipes AA or BB is closed into the control valves. increase in throttle governing of steam turbine
-

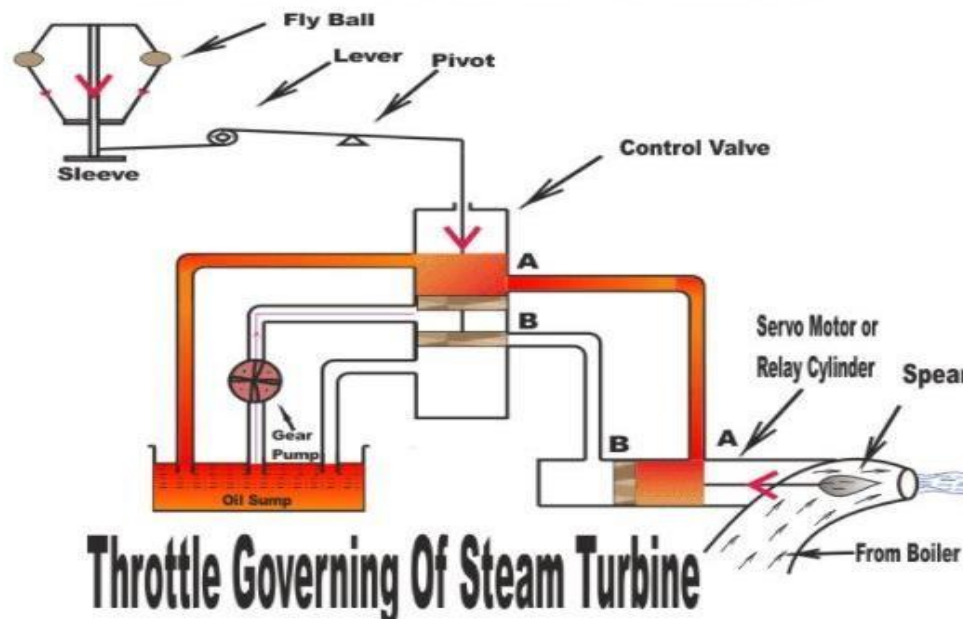

Fig : When Load increase on Turbine

- Assume that the turbine's load increases. It will decrease its speed which will decrease the centrifugal force of the turbine.
- Now fly balls of the governor will come down thus decreasing their amplitude. These fly balls also bring down the sleeve.
- The sleeve is connected to a control valve rod through a lever pivoted on the fulcrum. This down word sleeve will raise the control valve rod.
- Now oil is coming from the from the oil sump, pumped by gear pump is just stay at the mounts of both pipes AA or BB which are closed by the two wings of control valves. So, raise of control valve rod will open the mouth of the pipe AA but BB is still closed.
- Now the oil pressure is coming from the pipe AA. This will rush from the control valve which will move the right side of the piston. As a result, the steams flow rate into the turbine increases which will bring the speed of the turbine to the normal range.
- When speed of the turbine will come to its normal range, fly balls will come into its normal position. Now, sleeve and control valve rod will back to its normal position.

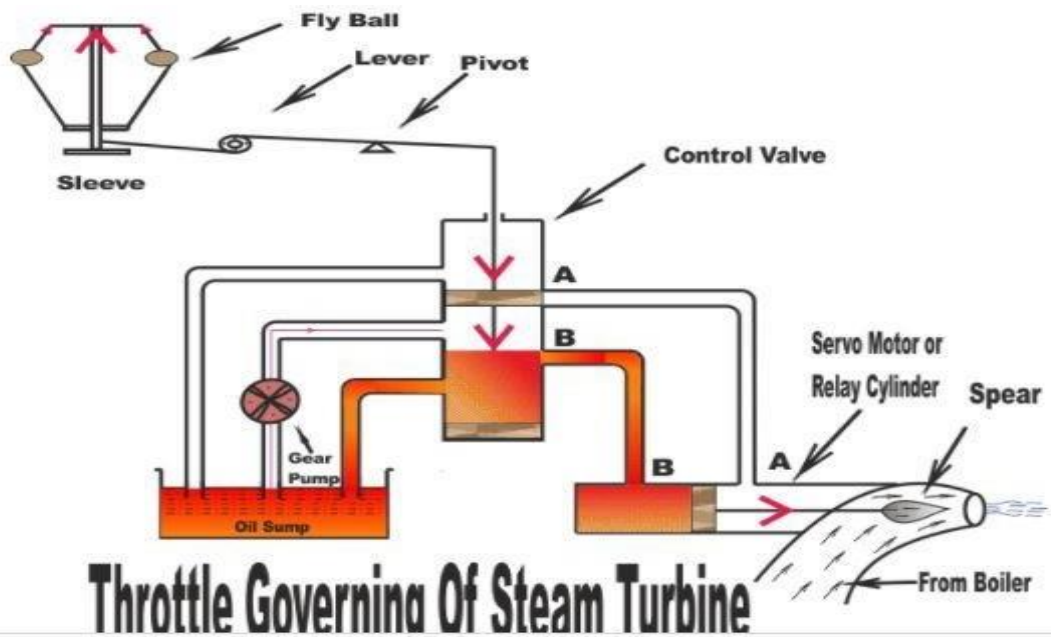
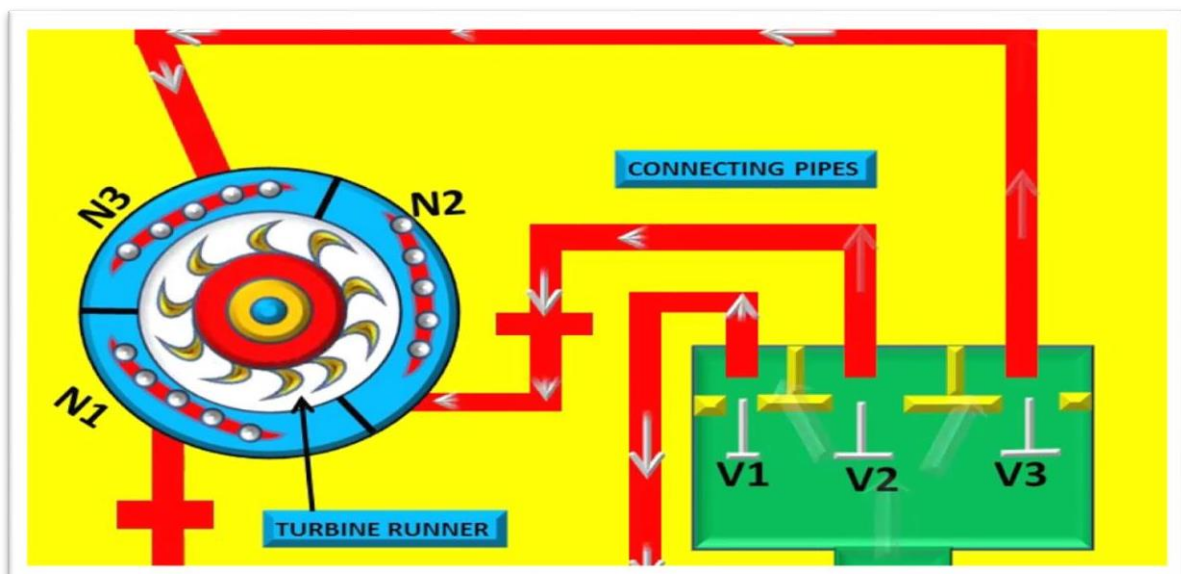

Fig : When Load Decrease on Turbine

2. Nozzle Control Governing Of Steam Turbine:-

- It is another interesting method by which turbine's speed can be controlled. Nozzle control governing of steam turbine is basically used for part load condition.
- Some set of nozzles are grouped together (may be two, three or more groups) and each group of the nozzle is supplied steam controlled by valves.
- Every valve is closed by the corresponding set of nozzle. Steam's flow rate is also controlled by these nozzles.



- Actually, nozzle control governing is restricted to the first stage of turbine whereas the subsequent nozzle area in other stage remains constant.
- According to the load demand, some nozzles are in active and other inactive position. Suppose turbine holds ten numbers of nozzles.
- If the load demand is reduced by 50% then five numbers of nozzles are in open condition and rest is closed.
- This method is suitable for SIMPLE IMPULSE TURBINE. It is a process where rate of steam flow is regulated depending on the opening and closing of set of nozzles rather than regulating its pressure.

3. Bypass Governing Of Steam Turbine:-

- Bypass governing of steam turbine is a method where a bypass line is provided for the steam.
- Especially this is used when turbine is running in overloaded condition. The bypass line is provided for passing the steam from first stage nozzle box into a later stage where work output increase.
- This bypass steam is automatically regulated by the lift of valve which is under the control of the speed of the governor for all loads within its range.
- Bypass valve is open to release the fresh steam into the later stage of the turbine. In the later stage output, work is increased and the efficiency is low due to the throttle effect.

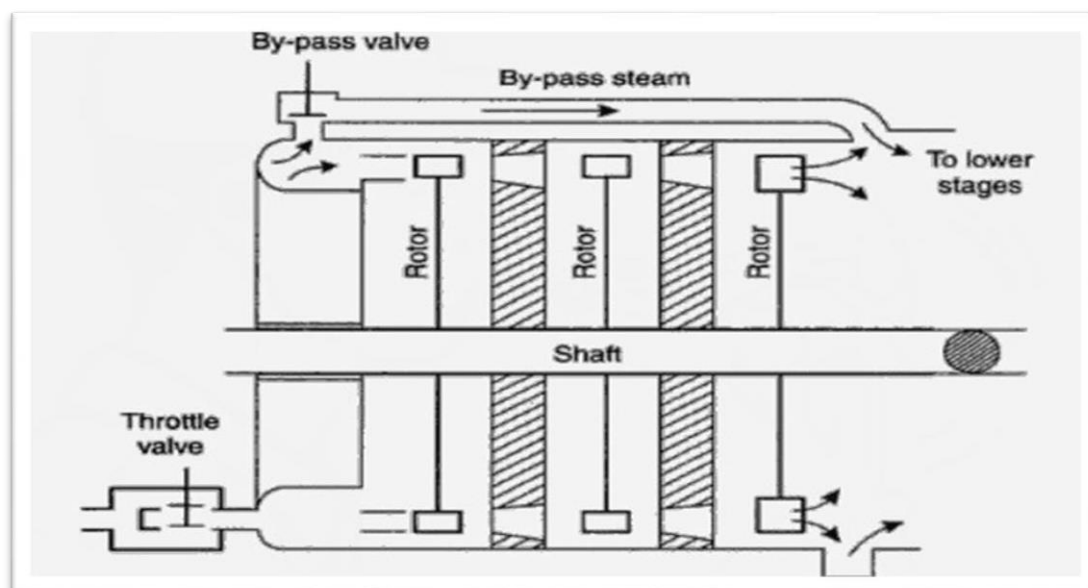

Performance of steam turbine:

Thermal efficiency

In general the thermal efficiency, η_{th} , of any heat engine is defined as the ratio of the work it does, W , to the heat input at the high temperature, Q_H .

$$\eta_{th} = \frac{W}{Q_H}$$

The thermal efficiency, η_{th} , represents the fraction of heat, Q_H , that is converted to work. Since energy is conserved according to the first law of thermodynamics and energy cannot be converted to work completely, the heat input, Q_H , must equal the work done, W , plus the heat that must be dissipated as waste heat Q_C into the environment. Therefore we can rewrite the formula for thermal efficiency as:

Thermal efficiency.

$$\eta_{th} = \frac{W}{Q_H} = \frac{Q_H - Q_C}{Q_H} = 1 - \frac{Q_C}{Q_H}$$

Stage efficiency :

$$\begin{aligned} \eta_{Stage} &= \frac{\text{Net workdone on shaft per stage per kg of steam}}{\text{Adiabatic heat drop per stage}} \\ &= \frac{\text{Net workdone on blades - Disc friction and windage}}{\text{Adiabatic heat drop per stage}} \end{aligned}$$

Overall or Turbine efficiency:

This efficiency covers internal and external losses. For examples bearing and steam friction, leakage, radiation

$$\eta_{Overall} = \frac{\text{Work delivered at the turbine coupling in heat unit per kg of steam}}{\text{Total adiabatic heat drop}}$$

Net efficiency or Gross efficiency :

$$\eta_{net} = \frac{\text{Brake thermal efficiency}}{\text{Thermal efficiency on the ranking cycle}}$$

Steam Condenser :

Steam Condenser:

It is a device or an appliance in which steam condenses and heat released by steam is absorbed by water.

Classification of Condensers

1. Jet condensers
2. Surface condenser

Jet Condensers:

The exhaust steam and water come in direct contact with each other and temperature of the condensate is the same as that of cooling water leaving the condenser. The cooling water is usually sprayed into the exhaust steam to cause, rapid condensation.

Surface Condensers:

The exhaust steam and water do not come into direct contact. The steam passes over the outer surface of tubes through which a supply of cooling water is maintained.

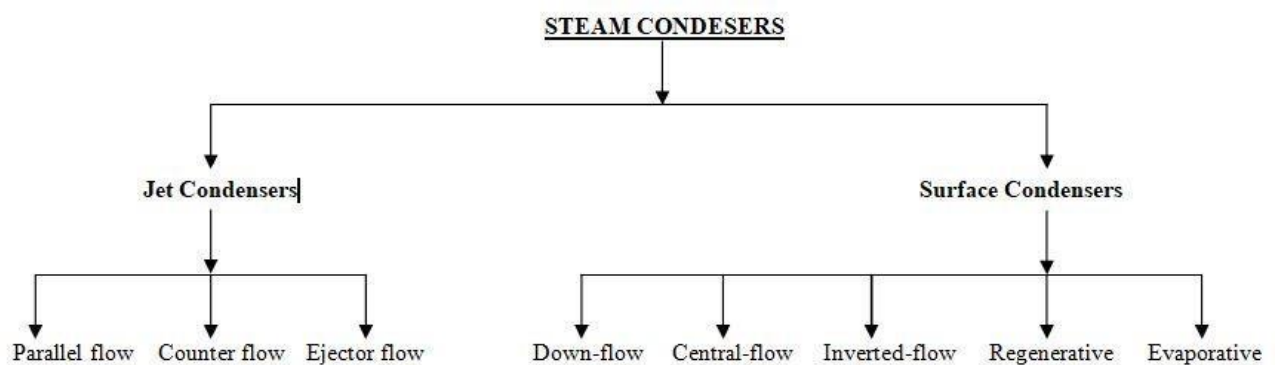

Parallel- Flow Type of Jet Condenser:

The exhaust steam and cooling water find their entry at the top of the condenser and then flow downwards and condensate and water are finally collected at the bottom.

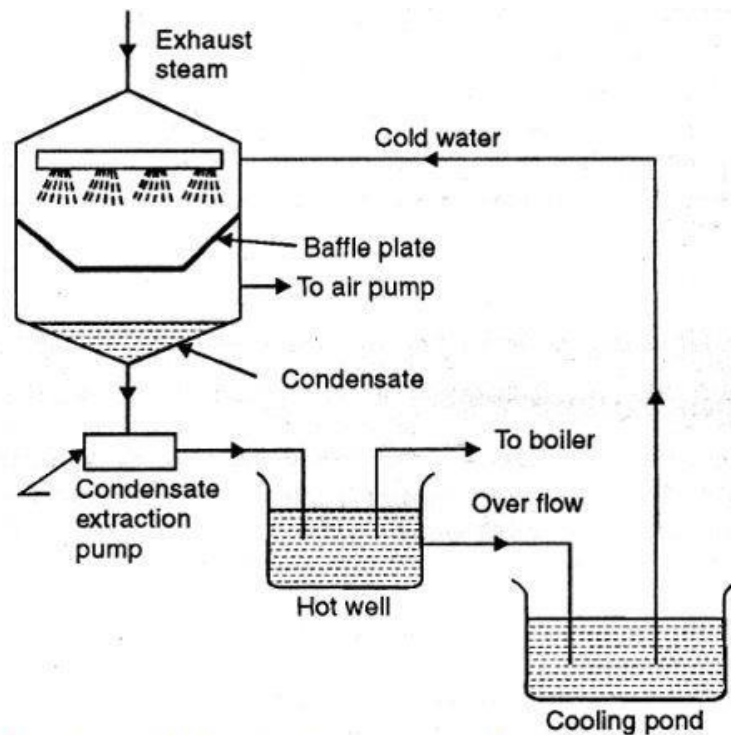

Fig. Parallel flow type condenser

Counter- Flow Type jet Condenser:

The steam and cooling water enter the condenser from opposite directions. Generally, the exhaust steam travels in upward direction and meets the cooling water which flows downwards.

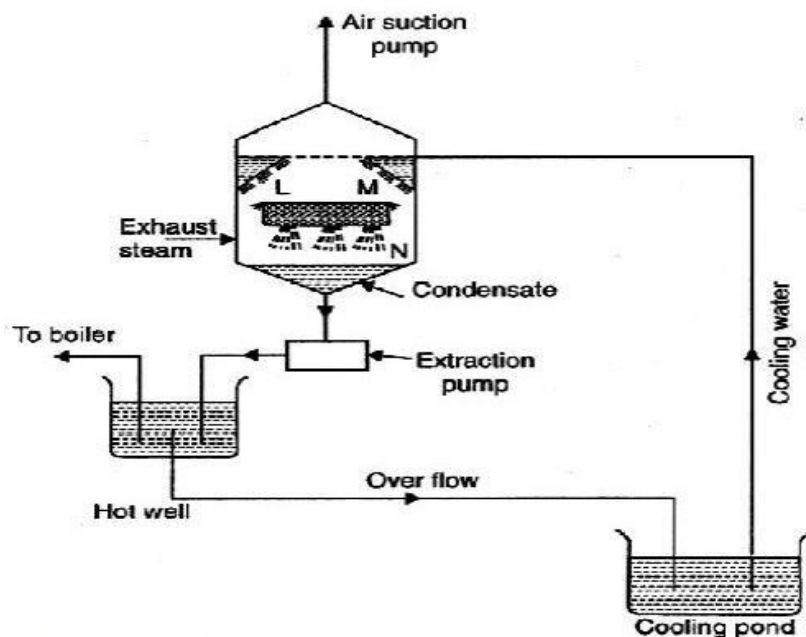

Fig. Low level counter flow type condenser

Low Level Jet Condenser (Counter-Flow Type Jet Condenser):

- Figure Shows, L, M and N are the perforated trays which break up water into jets. The steam moving upwards comes in contact with water and gets condensed.
- The condensate and water mixture is sent to the hot well by means of an extraction pump and the air is removed by an air suction pump provided at the top of the condenser.

High Level Jet Condenser (Counter-Flow Type Jet Condenser):

- It is also called barometric condenser. In this type the shell is placed at a height about 10.363 meters above hot well and thus the necessity of providing an extraction pump can be obviated. However provision of own injection pump has to be made if water under pressure is not available.

Ejector Condenser Flow Type Jet Condenser:

- Here the exhaust steam and cooling water mix in hollow truncated cones. Due to this decreased pressure exhaust steam along with associated air is drawn through the truncated cones and finally lead to diverging cone.

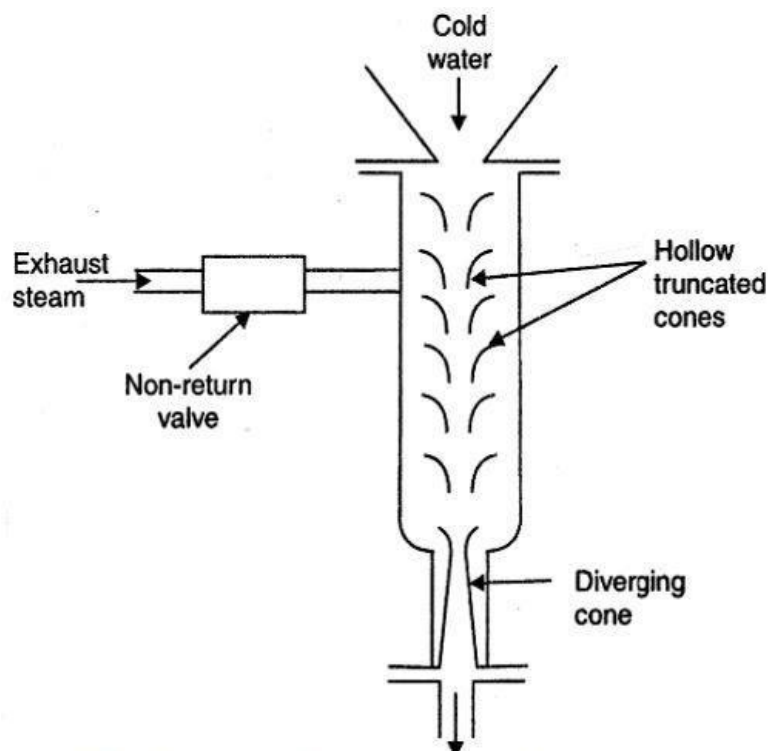

Fig. Ejector flow type condenser

- In the diverging cone, a portion of kinetic energy gets converted into pressure energy which is more than the atmospheric so that condensate consisting of condensed steam, cooling water and air is discharged into the hot well.
- The exhaust steam inlet is provided with a non-return valve which does not allow the water from hot well to rush back to the engine in case a failure of cooling water supply to condenser.

Down-Flow Type:

- The cooling water enters the shell at the lower half section and after traveling through the upper half section comes out through the outlet. The exhaust steam entering shell from the top flows down over the tubes and gets condensed and is finally removed by an extraction pump. Due to the fact that steam flows in a direction right angle to the direction of flow of water, it is also called cross-surface condenser.

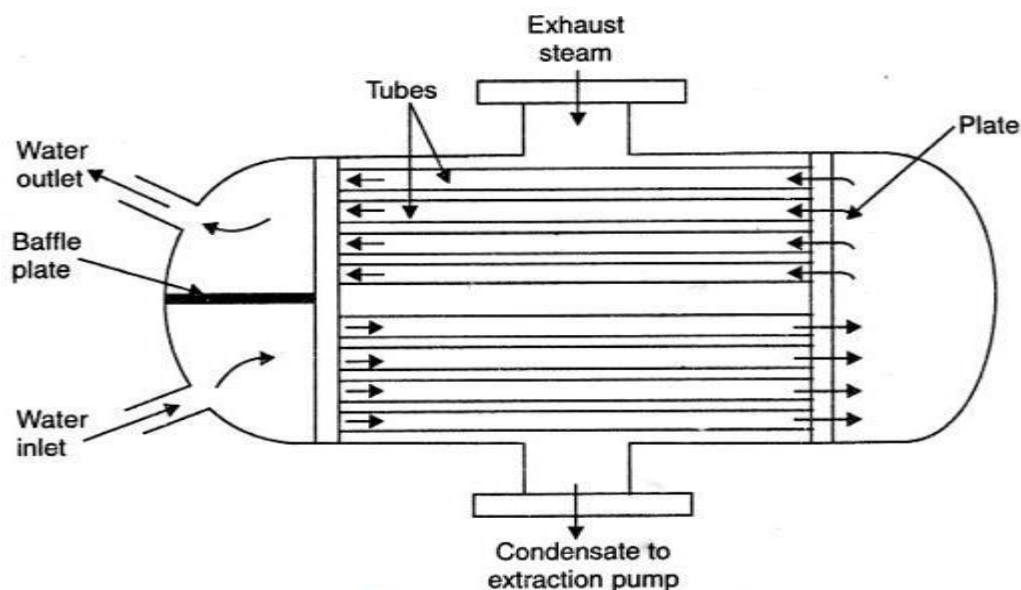

Fig. Down-Flow Type

Central Flow Type:

- In this type of condenser, the suction pipe of the air extraction pump is located in the centre of the tubes which results in radial flow of the steam. The better contact between the outer surface of the tubes and steam is ensured; due to large passages the pressure drop of steam is reduced.

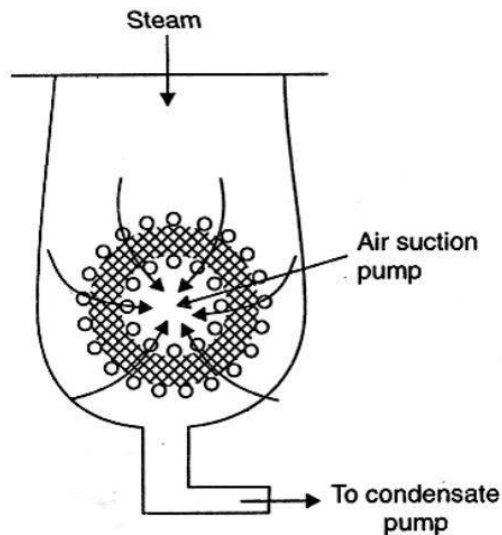

Fig. Central Flow Type

Evaporative Type:

- The principle of this condenser is that when a limited quantity of water is available, its quantity needed to condense the steam can be reduced by causing the circulating water to evaporate under a small partial pressure.
- The exhaust steam enters at the top through gilled pipes. The water pump sprays water on the pipes and descending water condenses the steam. The water which is not evaporated falls into the open tank (cooling pond) under the condenser from which it can be drawn by circulating water pump and used over again.
- The evaporative condenser is placed in open air and finds its application in small size plants.

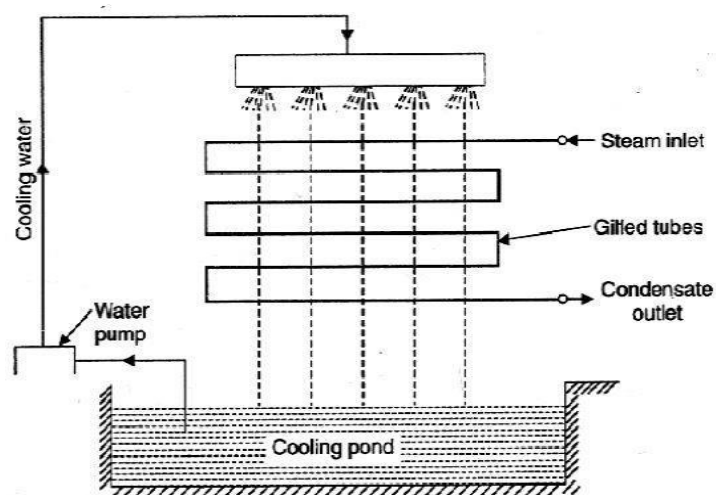

Fig. Evaporative Type

Inverted Flow Type:

- This type of condenser has the air suction at the top; the steam after entering at the bottom rises up and then again flows down to the bottom of the condenser, by following a path near the outer surface of the condenser. The condensate extraction pump is at the bottom.

Regenerative Type:

- This type is applied to condensers adopting a regenerative method of heating of the condensate. After leaving the tube nest, the condensate is passed through the entering exhaust steam from the steam engine or turbine thus raising the temperature of the condensate, for use as feed water for the boiler.

Function of condenser auxiliaries:

1. Condense: It is a closed vessel in which steam is condensed. The steam gives up heat energy to coolant (which is water) during the process of condensation.
 2. Condensate pump: It is a pump, which removes condensate (i.e. condensed steam) from the condenser to the hot well.
 3. Hot well: It is a sump between the condenser and boiler, which receives condensate pumped by the condensate pump.
 4. Boiler feed pump: It is a pump, which pumps the condensate from the hot well to the boiler. This is done by increasing the pressure of condensate above the boiler pressure.
 5. Air extraction pump: It is a pump which extracts (i.e. removes) air from the condenser.
 6. Cooling tower: It is a tower used for cooling the water which is discharged from the condenser.
-

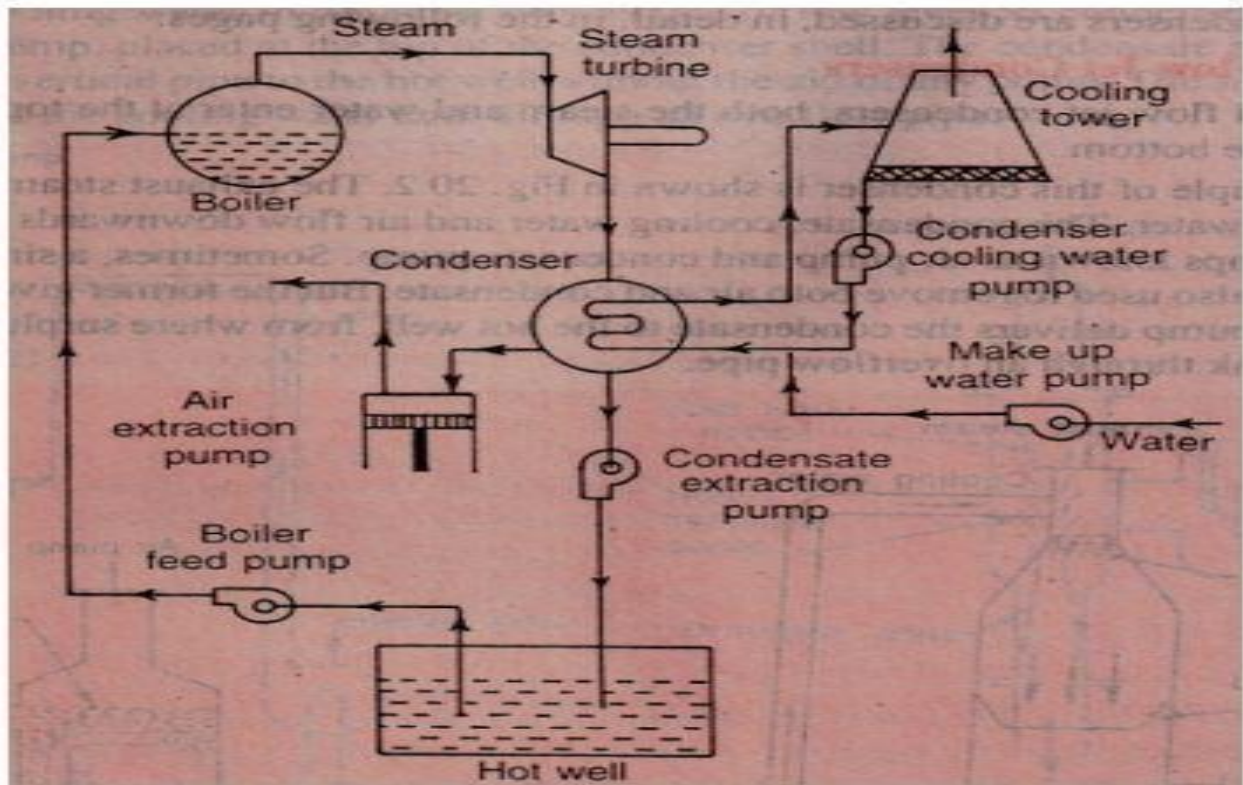

Elements of a steam condensing plant:

Cooling Towers

- In Power plants the hot water from condenser is cooled in cooling tower, so that it can be by reused In condenser for condensation of steam.
- In a cooling tower water is made to trickle down drop by drop so that it comes in contact with the air moving in the opposite direction. As a result of this some water is evaporated and is taken away with air. In evaporation the heat is taken away from the bulk of water, which is thus cooled.

The cooling towers may also be classified as follows :

A. Natural draught cooling towers

B. Mechanical draught cooling towers :

- I. Forced draught cooling towers
- II. Induced draught cooling towers.

A. Natural draught cooling tower.

- In this type of tower, the hot water from the condenser is pumped to the troughs and nozzles situated near the bottom. Troughs spray the water falls in the form of droplets into a pond situated at the bottom of the tower.
- The air enters the cooling tower from air openings provided near the base, rises upward and takes up the heat of falling water. A concrete hyperbolic cooling tower is shown in figure. This tower has the following advantages over mechanical towers :

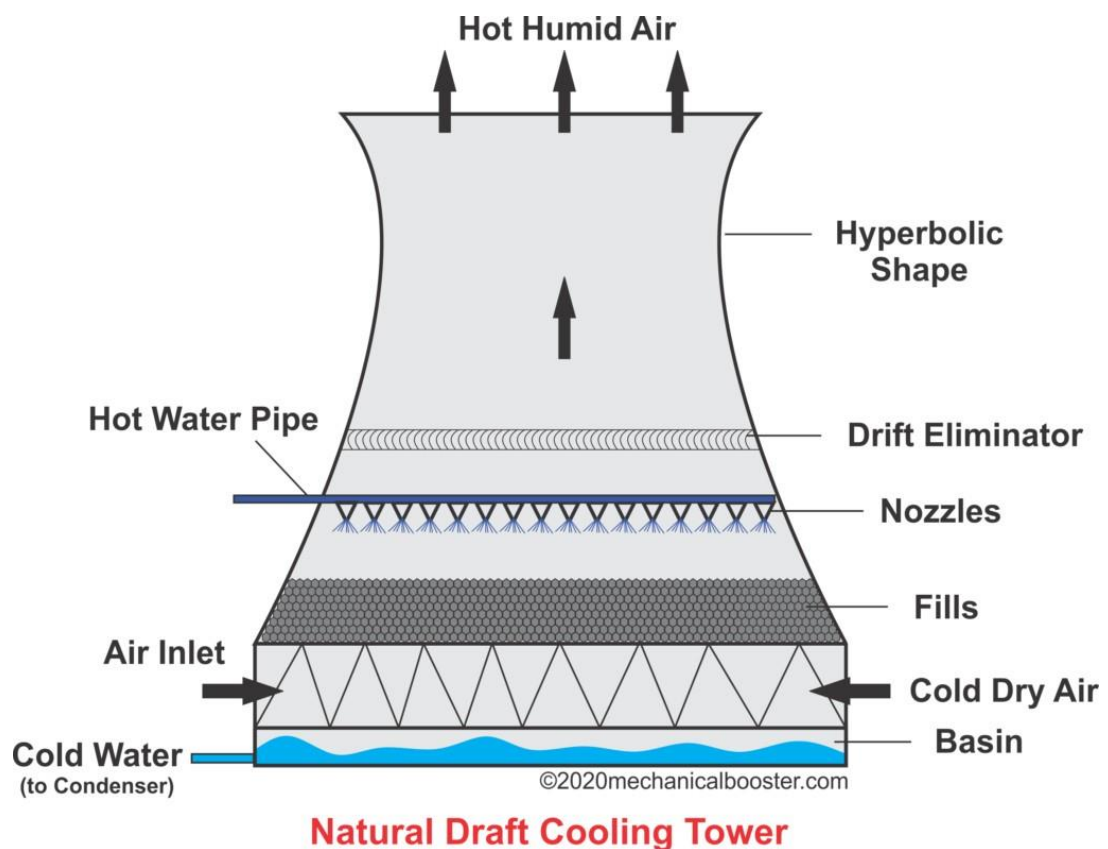

- Low operating and maintenance cost.
- It gives more or less trouble free operation.
- Considerable less ground area required.
- The towers may be as high as 125 m and 100 m in diameter at the base with the capability of withstanding winds of very high speed. These structures are more or less self-sup-ported structures.
- The enlarged top of the tower allows water to fall out of suspension.

The main **drawbacks** of this tower are listed below :

- High initial cost.
-

- Its performance varies with the seasonal changes in DBT (dry bulb temperature) and R.H. (relative humidity) of air.

While initial cost may be higher, the saving in fan power, longer life and less maintenance always favour for this type of tower. **It is also more favourable** over mechanical draught cooling towers as central station size increases.

B. Mechanical draught cooling towers.

- In these towers the draught of air for cooling the tower is produced mechanically by means of propeller fans.
- These towers are usually built in cells or units, the capacity depending upon the number of cells used.
- Figure shows a forced draught cooling tower.
- It is similar to natural draught tower as far as interior construction is concerned, but the sides of the tower are closed and form an air and water tight structure, except for fan openings at the base for the inlet of fresh air, and the outlet at the top for the exit of air and vapours.
- There are hoods at the base projecting from the main portion of the tower where the fans are placed for forcing the air, into the tower.

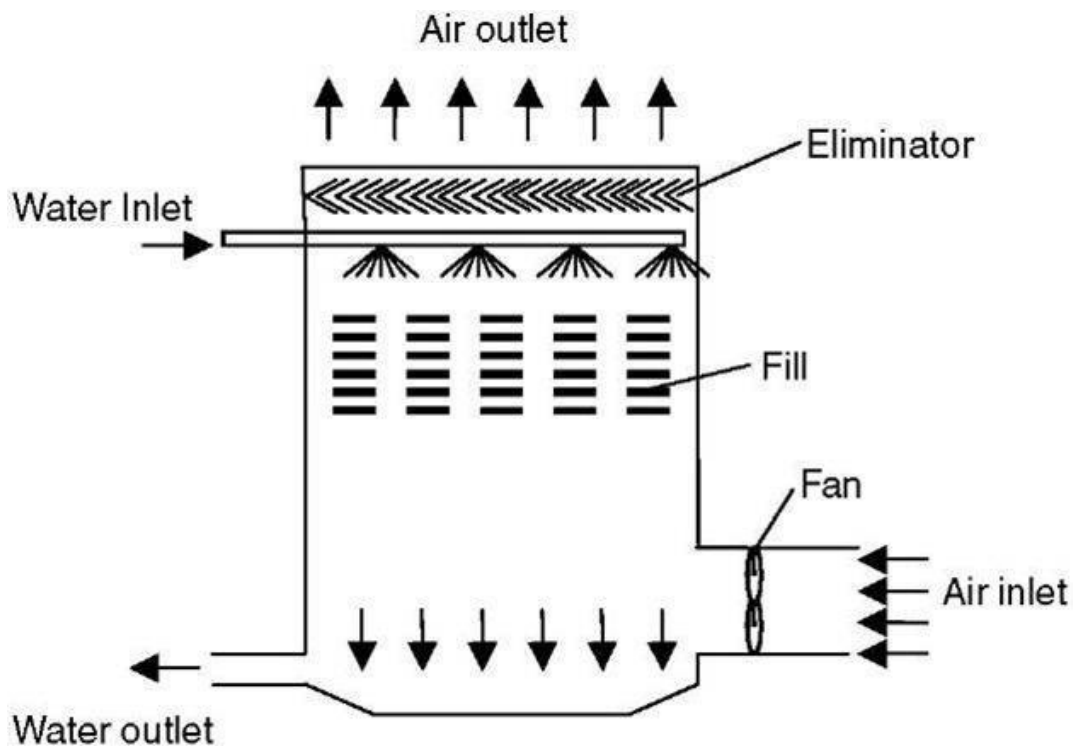
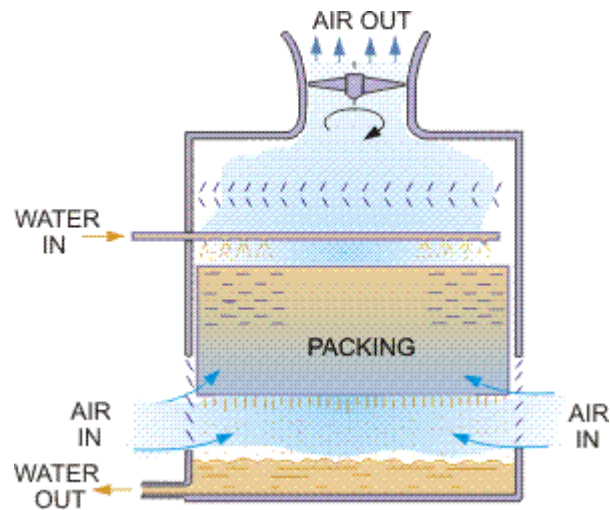

Fig : Forced draught cooling tower

Below Figure shows an induced draught cooling tower. In these towers, the fans are placed at the top of the tower and they draw the air in through louvers extending all around the tower as its base.



Comparison of forced and induced draught tower

Forced Draught Cooling Towers

Advantages :

1. More efficient (than induced draught).
2. No problem of fan blade erosion (as it handles dry air only).
3. More safe.
4. The vibration and noise are minimum.

Disadvantages :

1. The fan size is limited to 4 metres.
 2. Power requirement high (approximately double that of induced draught system for the same capacity).
 3. In the cold weather, ice is formed on nearby equipments and buildings or in the fan housing itself. The frost in the fan outlet can break the fan blades.
-

Induced draught cooling towers

Advantages :

1. The coldest water comes in contact with the driest air and warmest water comes in contact with the most humid air. 2. In this tower, the recirculation is seldom a problem.
2. Lower first cost (due to the reduced pump capacity and smaller length of water Pipes)
3. Less space required.
4. This tower is capable of cooling through a wide range.

Disadvantages

1. The air velocities through the packings are unevenly distributed and it has very little movement near the walls and centre of the tower.
2. Higher H.P. motor is required to drive the fan comparatively. This is due to the fact that the static pressure loss is higher as restricted area at base tends to choke off the flow of higher %velocity air.

Comparison between Natural and Mechanical Draught Towers Mechanical draught towers

Advantages :

1. These towers require a small land area and can be built at most locations.
2. The fans give a good control over the air flow and thus the water temperature.
3. Less costly to install than natural draught towers.

Disadvantages :

1. Fan power requirements and maintenance costs make them more expensive to operate.
 2. Local fogging and icing may occur in winter season.
-

Spray Ponds

- In this system warm water received from the condenser is sprayed through the nozzles over a pond of large area and cooling effect is mainly due to evaporation from the surface of water. In this system sufficient amount of water is lost by evaporation and windage.

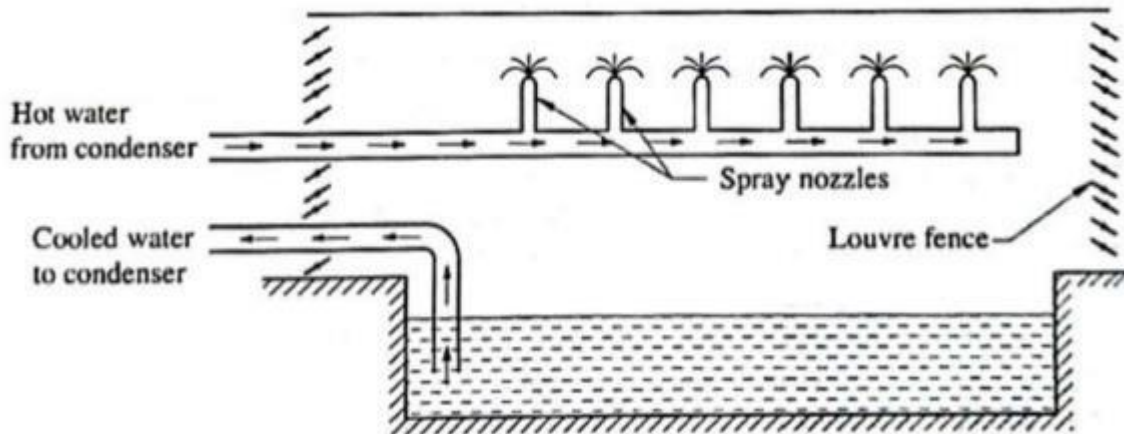

Fig : Spray ponds

- The spacing of the nozzle in spray pond depends upon the design and size of the nozzles. Centrifugal nozzles of 50 mm size are usually spaced about 3 metres from centre to centre but the nozzles of large size may be set proportionally farther apart.
- Nozzles may be mounted in groups of four or five.

Disadvantages of cooling and spray ponds

1. A considerably large area required for cooling.
 2. High spray losses (due to evaporation and windage).
 3. No control over the temperature of cooled water.
 4. Low cooling efficiency (as compared with cooling tower).
-

2.11 Selection of site for a thermal power plant:

- (i) **Close to load centre:** The site selected should be as close to the load as possible. This minimizes voltage drop and transmission and distribution losses.
- (ii) **Availability of large quantity of water:** A thermal power plant requires large quantity of water for cooling and as feed water in boiler. Therefore, the selected site should be close to a continuous source of water such as river, canal, lake etc.
- (iii) **Availability of large area:** Large area is required to set-up a thermal power plant to accommodate power plant, coal storage and handling yard, ash handling and disposal yard, staff quarters etc. Hence, sufficient land should be available at reasonable price. Moreover, the land should be free from ater logging and soil should have good bearing capacity to permit installation of heavy equipments.
- (iv) **Availability of coal:** The site selected should be near to a coal mine so as to minimize cost of transportation of coal.
- (v) **Availability of transportation facility:** The site selected should be near to rail head, road, river or sea so as to allow easy transportation of coal, plant and machinery, building construction material etc.
- (vi) **Availability of large area for ash disposal:** A thermal power plant generates large quantity of ash everyday which needs large area for disposal. Therefore, the site should have large area for ash disposal.
- (vii) **Distance from populated area:** The selected site should be away from habitat due to pollution.
- (viii) **Availability of skilled and unskilled manpower:** The selected site should be such that required skilled and unskilled manpower is easily available for construction and operation.
- (ix) **Geologically stable area:** The site should be away from seizmic area, landslide zone, flood prone zone etc.

IMPORTANT QUESTIONS

1. Explain advantages and disadvantages of thermal power generation.
 2. Discuss various types of losses taking place in a thermal power plant.
 3. \\Mai are the features which govern the choice of site for a thermal power plant?
 4. Draw the block diagram of thermal power plant and explain its working.
 5. Describe function of electrostatic precipitator (ESP). 6. Describe advantages of pulverised fuel firing.
 7. Why superheated steam is used in steam turbine?
 8. Describe construction and working of air preheater and economiser.
 9. Discuss purpose and types of deaerators.
 10. Write brief note on: (i) ball mill, (ii) impact mill.
 11. Differentiate between quality of water used in boiler drum and cooling tower.
 12. Write brief note on power plant instrumentation.
 13. Write brief note on various protections provided in an alternator.
 14. Discuss auxiliaries used in a thermal power plant.
 15. Write a brief note on fluidised bed combustion boiler. 16. Differentiate between sub critical, super critical and ultra super critical boilers.
 17. Compare impulse and reaction steam turbines.
 18. Discuss the use of barring gear motor.
 19. Why surface type condensers are preferred over jet type condensers for powerplant applicati
 20. Write brief note on ultra mega power plants.
 21. What are various pollution control techniques used in a thermal power Plant?
 22. Discuss various factors affecting selection of height of stack in a thermal power plant.
-

Short Questions

1. Write five advantages of pulverised fuel firing.
 2. Why diameter of steam drum is smaller than water drum?
 3. Why superheated steam is used in steam turbine rather than saturated steam?
 4. What is the function of induced draught and forced draught fans in a boiler?
 5. What is the purpose of using deaerator in a boiler?
 6. Describe four uses of furnace bottom ash.
 7. Why efficiency of thermal power plant is low?
 8. Why finned tubes are used in a boiler?
 9. What is the purpose of using blow down in a boiler?
 10. Differentiate between DM water and soft water.
-

Chapter – 03

NUCLEAR POWER STATION

The Power station which uses nuclear energy of radioactive material (Uranium or Thorium) converted into Electrical Energy is known as Nuclear Power station.

Classification of nuclear fuel:

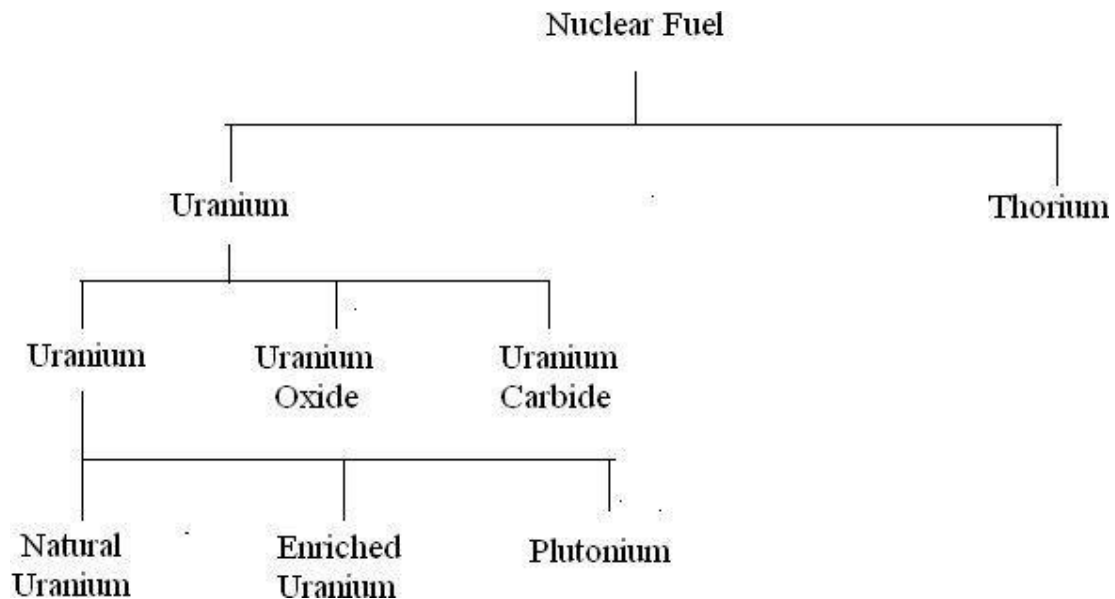

Uranium & its properties:

Atomic Number: 92

Melting Point: 1408 K (1135°C or 2075°F)

Boiling Point: 4404 K (4131°C or 7468°F)

- Uranium is a very important element because it provides us with nuclear fuel used to generate electricity in nuclear power stations.
- Naturally occurring uranium consists of 99% Uranium-238 and 1% uranium-235. Uranium-235 is the only naturally occurring fissionable fuel (a fuel that can sustain a chain reaction).

Natural Uranium: it consists of 0.714% of ${}_{92}^{235}\text{U}$ and 99.28% of ${}_{92}^{238}\text{U}$

Enriched Uranium: The Process used to increase the percentage of ${}^{235}_{92}\text{U}$ is known as enrichment. This will help us to maintain chain reaction. Normally it contains higher percentages (3 to 4%) of ${}^{235}_{92}\text{U}$

Plutonium: Due to the absorption of neutrons without fusion in ${}^{235}_{92}\text{U}$ & ${}^{232}_{90}\text{Th}$ the plutonium (${}^{234}_{94}\text{Pu}$) is formed. Atomic Number: 94, Melting point: 641 °C, Boiling point: 3232 °C

Uranium oxide: it is also formed due to enrichment process, but it is in brittle & produced in the form of powder.

Uranium Carbide: this material is not economical in use, but it has very good properties to use as nuclear fuel.

Thorium & its properties:

Atomic Number: 90

Melting Point: 1750 °C

Boiling Point: 4790 °C

- =/A weakly radioactive, silvery metal.
- Before it uses of Thorium ${}^{232}_{90}\text{Th}$ first up all converted into ${}^{233}_{92}\text{U}$
- Thorium is weakly radioactive: all its known isotopes are unstable, with the six naturally occurring ones (thorium-227, 228, 230, 231, 232, and 234).
- India and China are in the process of developing nuclear power plants with thorium reactors, but this is still a very new technology.
- Thorium has higher cost that's why it is not popular.

Fissile and Fertile Material

- The material which undergo nuclear fission readily are called fissile materials. These materials are Uranium-235, Uranium-233 and Plutonium-239. These are available in nature
 - Fertile materials are those materials which are not fissionable but
-

can be converted into fissionable form.

- Fertile materials are Uranium-238 and Thorium-232.
- Uranium-238 can be converted into Uranium-235 which is fissionable material.
- Thorium-232 can be converted into plutonium-239 which is fissionable material

Fission reaction and Fusion reaction :

Fission reaction :

- Fission reaction is used to produce energy in nuclear reactor
- When neutron hits a nucleus of fissile material, huge amount of energy is released due to breaking up of atom of fissile material. This reaction is called fission reaction.
- The nucleus ejects neutrons which further hit other atoms of fissile material and this process goes on resulting in further release of energy. This reaction is called chain reaction.
- In fission reaction neutrons and Gamma rays are emitted.
- Fission reaction always release energy.
- Controlled fission reaction is used to generate power in nuclear power station.

Fusion reaction :

- It is a process of combining two lighter nuclei into a stable and heavier nuclide
 - Here also a large amount of energy is released because mass of the product nucleus is less than the masses of the two nuclei which is fused.
-

Explain the working of nuclear power plant:

- A nuclear power plant is similar to a thermal power plant except that heat required to generate steam is obtained from chemical reaction in a reactor while coal is burnt in a thermal power plant to raise steam in a boiler. All other components such as steam turbine, generator, condenser, cooling tower etc., are similar.
- A major portion of a nuclear power plant is occupied by special facilities such as fuel element fabrication area , fuel element preparation area, radioactive waste storage area, waste disposal apparatus area, storage area for fuel, coolant and moderator.
- A nuclear power plant consists of following major components:
 - (i) Reactor,
 - (ii) Steam generator or heat exchanger,
 - (iii) Steam turbine,
 - (iv) Condenser,
 - (v) Cooling tower,
 - (vi) Generator,
 - (vii) Refueling pool,
 - (viii) Spent fuel pool,
 - (ix) Nuclear reactor safety systems.

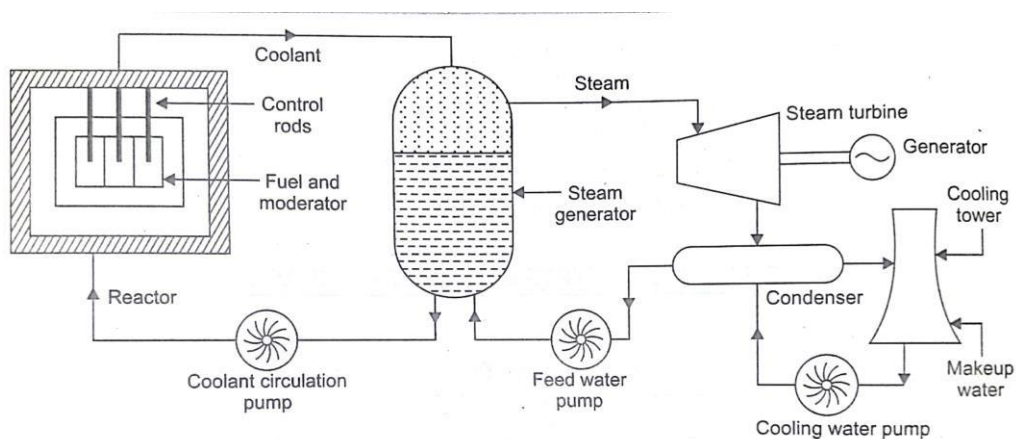

(i) **Reactor:** Nuclear fission reaction takes place inside a reactor. The heat generated due to chemical reaction is carried away by a coolant to a heat exchanger or boiler where steam is raised. Reactor is built with a core having fuel pellets and coolant surrounds the fuel pellets. Control rods are used to regulate the speed of chain reaction. A number safety mechanism is built in to protect the core from abnormal operation.

(ii) **Steam generator** or boiler or heat exchanger. It is a water filled vessel where coolant transfers the heat of fission reaction from reactor. The steam raised in the boiler and superheated in a superheater before feeding to steam turbine.

(iii) **Steam turbine.** The superheated steam from boiler is fed to steam turbine where it expands over a series of blades producing mechanical motion. Hence, heat energy contained in superheated steam is converted into mechanical energy.

(iv) **Condenser.** It is a heat exchanger in which exhaust steam after expansion in a steam turbine is condensed back to water. The heat of exhaust steam is carried away by cooling water. This cooling water dissipates heat into the atmosphere through a cooling tower.

(v) **Cooling tower.** Cooling water from condenser carrying heat of exhaust steam gets cooled in a cooling tower. The hot cooling water from condenser is sprayed from a height into the cooling tower. Water while falling down through falls gets converted into small droplets which increases the cooling surface area. A part of this water is evaporated and small part is lost due to drift (water droplets carried away by air). This loss of water is compensated by feeding makeup water into the cooling tower.

(vi) **Generator.** It is a synchronous generator coupled to steam turbine running at 3000 rpm producing electricity at 50 Hz frequency.

(vii) **Refueling pool.** In this area, loading of fresh fuel into the reactor is carried out by a robot.

(viii) **Spent fuel pool.** In this area, spent fuel from reactor is stored before it is disposed off.

(ix) **Nuclear reactor safety system.** A nuclear reactor is designed to contain harmful radiations within itself even under emergency situation. A number of safety systems are incorporated into the operation of reactor. Some of the safety systems are following:

- Reactor protection system
 - Emergency core cooling system
 - Reactor poisoning system to immediately stop nuclear chain reaction by injecting chemicals into reactor.
 - Emergency diesel generators to feed power to critical components such as cooling water pumps, emergency lighting etc.
-

Construction and working of nuclear reactor:

Construction :

A nuclear reactor is a device where nuclear fission reaction takes place. The heat of nuclear fission is removed by coolant to a heat exchanger. It is a heavy tank like structure which can withstand high pressure and radiation. The reactor has a central part called core which contains, fuel, moderator, reflector and coolant.

- Commonly used fuel in a reactor are: natural uranium U235 and enriched uranium (2 to 5% of U235). A moderator is used to slow down high energy neutrons liberated in fission reaction. The heat of fission reaction is removed by a coolant.

Core:

- Core is surrounded by neutron reflector material called shielding material which confines escaping neutrons back to the core.
- Reactor core is housed in dome shaped building with double walled concrete construction. The annular space between double walled concrete construction is kept at vacuum through filtration and pump back system to ensure zero radiation leak in the worst case scenario of an accident.
- Reactor is made of horizontal cylindrical vessel of stainless steel (SS 304 L) construction having horizontal coolant channels. These coolant channels made of Zirconium-Niobium alloy contain fuel bundles. Coolant is circulated around these fuel bundles to transfer heat to a secondary coolant. Is
- A fuel pin containing uranium oxide surrounded by Zirconium cladding is placed inside a fuel bundle. The fuel bundles are housed in a calandria (a horizontal cylindrical vessel having large number of holes for containing fuel pins holding uranium oxide).

Fuel: Fuel used are uranium-235, uranium-233 and plutonium-239. Fuel is assembled in the form of rods called fuel pins for easy insertion and removal from calandria.

Moderator: A moderator is used to slow down fast moving neutrons so that fission reaction can take place with natural uranium as fuel. Various types of moderator used are: heavy water, graphite, beryllium etc. Heavy water or deuterium oxide is

made from light water or 30 litres of light is used to produce one litre of heavy water.

Control rods: Control rods are used to control rate of fission reaction so that chain reaction is maintained at a steady pace. These rods are lowered into the reactor to reduce rate of reaction and are used to shut down the reactor during emergency. The material of these rods absorb neutrons released during nuclear fission such as boron, cadmium, hafnium etc. These rods are motorised and are controlled automatically.

Coolant: Coolant is a medium such as liquid sodium, helium, carbon dioxide, or heavy water which removes heat of chain reaction and transfers this heat to a heat exchanger or boiler. This boiler produces steam for steam turbine.

Reflector: Inside surface of reactor is covered with reflector which prevents escape of neutrons from reactor core. This prevent radiation leak from the core to surrounding atmosphere.

Shielding: It prevents leakage of radiation to surrounding atmosphere.

Containment: It is a heavy concrete and steel structure that prevents leakage of radiation to atmosphere during malfunction in reactor.

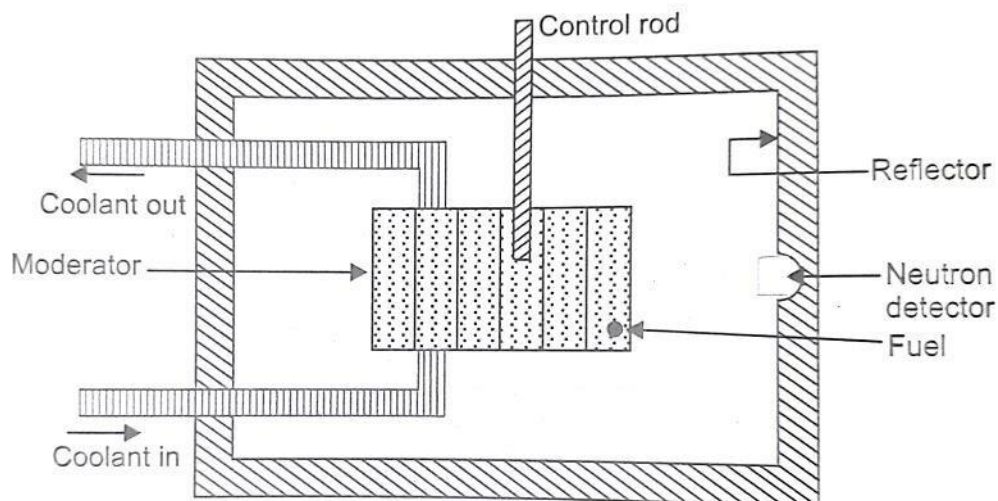
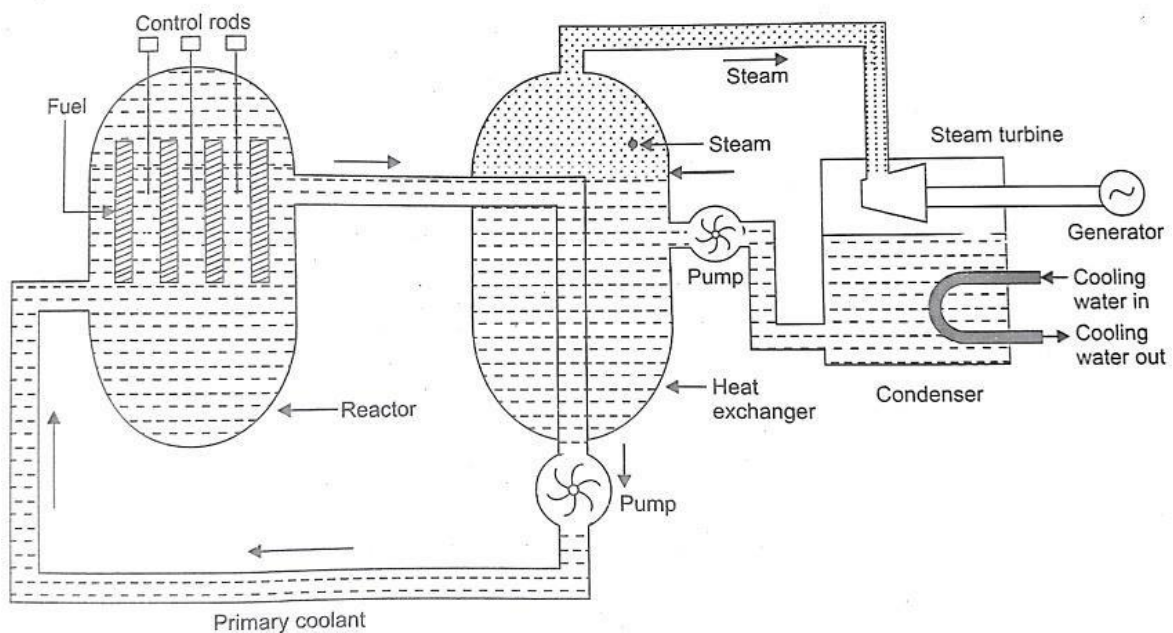

Fig. Reactor core

Pressurised Water Reactor (PWR) :

PWR uses ordinary water as coolant and moderator. Water is pressurised to about 150 atmosphere to prevent boiling of water, The temperature of water in the reactor is about 325°C. The cooling circuit consists of Primary and secondary circuits. The primary circuit water flows through core of reactor at high pressure while secondary circuit is used to generate steam.



Pressurised water reaction (PWR)

Primary cooling circuit contains a pressuriser in the form of pressure vessel with a heating coil at the bottom with water spray arrangement at the top. If primary circuit pressure decreases, heating coil gets on and generates steam by boiling water. This increases steam pressure. If pressure is high, cold water is sprayed in pressuriser to condense the steam. The type of reactor is used for power generation and marine propulsion.

Advantages of PWR

- (i) Compact size.
 - (ii) High power density.
 - (iii) Low cost of coolant and moderator as ordinary water is used.
 - (iv) Good response to increase in load demand.
-

- (v) Reactor cools down if water starts bubbling.
- (vi) Plutonium breeding can be done by providing a blanket of Uranium-238.

Disadvantages of PWR

- (i) Production of low temperature steam (250°C).
- (ii) Chances of coolant leakage due to high pressure. To prevent corrosion, expensive cladding material is required. Reactor needs to be shutdown for Fuel recharging. High auxiliary power consumption.

Boiling Water Reactor (BWR)

A boiling water reactor uses enriched uranium oxide as fuel and ordinary water as coolant and moderator it uses single cooling circuit with water at a pressure of 75 atmosphere and temperature of 285°C .

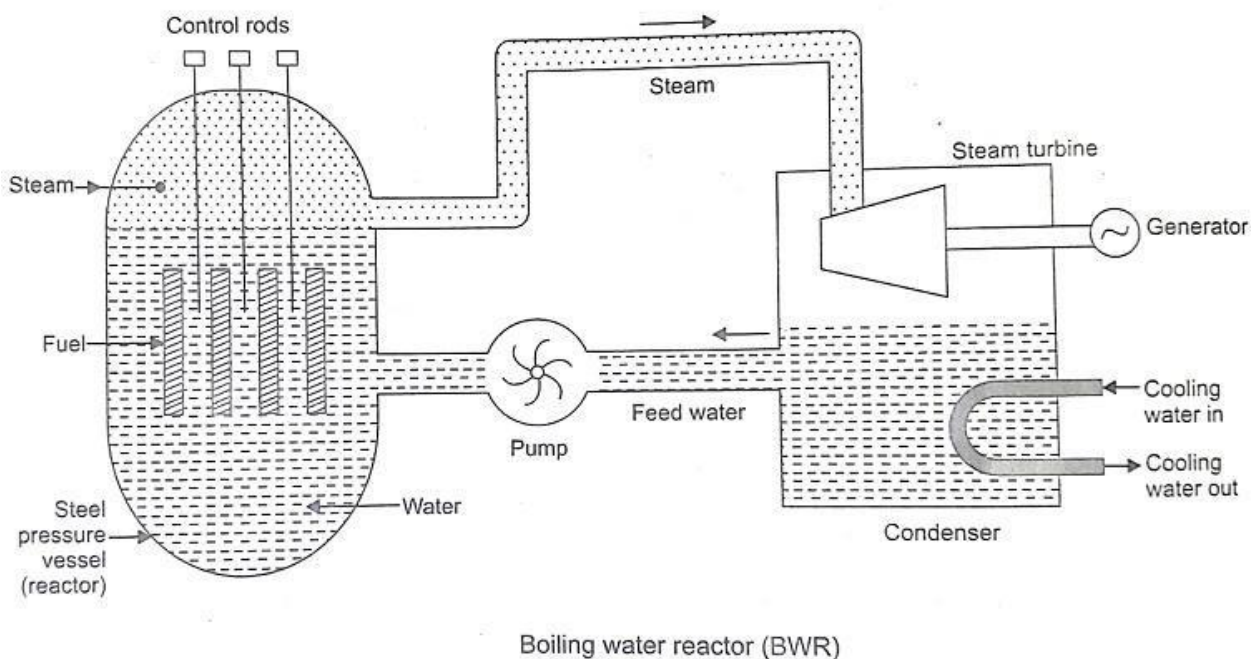

Feed water enter at the bottom and gets evaporated into steam due to heat of fission reaction. This steam leaves the reactor at the top and enters steam turbine. After expansion of steam in steam turbine, it gets condensed in a water cooled condenser and fed back to heat exchanger as feed water, Duo to radioactive contamination around the reactor core, radiological protection is provided to Steam turbine

Advantages of BWR

1. Size of pressure vessel is small due to single cooling water circuit.
2. High thermal efficiency (about 30%).
3. Less pressure in reactor vessel resulting in lower chances of leakage and cheaper design
4. Temperature of metal surface is lower as the boiling of water takes place inside reactor.
5. Operation of BWR is more stable.

Disadvantage of BWR

1. Possibility of radioactive contamination in steam turbine due to pressure of single cooling circuit.
2. Size of BWR is more compared to PWR.
3. As the boiling of water takes place at the surface of the fuel, chances of fuel burnout is possible.
4. It can not cope up with sudden increase in load.

Compare the nuclear and thermal power plants:

Thermal power station:

Principle of operation: It works on Modified Rankine Cycle.

Location: It is located at a site where coal, water and transportation facilities are available easily. It is located near load centers.

Requirement of Space: Need a large space due to coal storage, turbine, boiler and other auxiliaries.

Efficiency: Overall efficiency is least compared to other plants. (30%-32%)

Fuel Used: Coal (mostly) or oil.

Availability of Fuel: Coal reserves are present all over the world. However, coal is non-renewable and limited.

Cost of Fuel: High. Coal is heavy and has to be transported to the plant.

Initial Cost of Plant: Lower than Hydroelectric and Nuclear power plants.

Running Costs: Higher than Hydroelectric and Nuclear power plants.

Maintenance Costs: High. Skilled engineers and staff are needed.

Transmission and Distribution Cost: Low. It is usually located near load centers.

Start-up Power: About 10% of unit capacity.

Starting time: Large

Standby Losses: More than hydroelectric and nuclear power plants. Boiler flame has to be kept burning, so some amount of coal is used constantly, even when the turbine is not in operation.

Cleanliness: Less clean. Smoke and ash are produced.

Environmental Considerations: Air pollution occurs and leads to acid rain. Greenhouse gases are also produced.

Life Time: 30 - 40 years.

Nuclear Power Station

Principle of operation: Thermonuclear fission.

Location: Located away from heavily populated areas.

Requirement of Space: Requires minimum space compared to other plants of the same capacity.

Efficiency: Higher than Thermal Power Station. About 55%

Fuel Used: Uranium (U235) and other radioactive metals.

Availability of Fuel: Deposits of nuclear fuel are present all over the world. Also, uranium can be extracted from sea water, but it's a complicated and complex process.

Cost of Fuel: Fuel (uranium) itself isn't too costly. However, if enriched uranium is used, then the cost of fuel increases considerably. A small amount of fuel is used, so transportation costs are less.

Initial Cost of Plant: Highest. A nuclear reactor is complex and requires the most skilled engineers.

Running Costs: Small amount of fuel used, so running cost is low.

Maintenance Costs: Very high. Skilled personnel are needed.

Transmission and Distribution Cost: Quite low. Such plants can be located near the load centers.

Start-up Power: 7% to 10% of unit capacity.

Starting time: Less than TPS. Can be started easily.

Standby Losses: Less.

Cleanliness: Radioactive waste is produced. Less clean than HPS.

Environmental Considerations: Disposal of radioactive wastes may affect the environment, especially if it is buried underground. Underwater

contamination may occur.

Life Time: 40-60 years.

Disposal of nuclear waste:

Based on this means the level of radioactivity material or radiations, nuclear waste management is classified into three types:

Classification of nuclear (Radioactive) Wastage:

1. Low Level Waste (LLW)
2. Intermediate Level Waste (ILW)
3. High Level Wastage (HLW)

LLW (Low Level Waste):

- In case of low level waste, the (% Content of Radioactivity) radioactive level is very less. Normally, this type of waste comes from industries, hospitals, small nuclear plant. At the time of handling & transport the low level waste, it does not require shielding. The low level waste buried in land with suitable depth at the time of disposal.

ILW (Intermediate Level Waste):

- The percentage of radioactivity is higher as compared with low level waste. At the time of handling & transportation shielding is required because, the produce radioactive are very difficult. It means that it's affected to human health. At the time of ILW disposal first up all it is placed in concrete container, after that it is well sealed. Finally the ILW is buried in underground facility.

HLW (High Level Waste):

- As compared with LLW & ILW, the HLW is very dangerous to handling as well as it is directly affected to human health. Most of accidents in nuclear power plants are occurred due to this HLW. At the time of handling it requires shielding as well as cooling. The HLW mainly comes from reprocessing of nuclear fuel in the reactor. The HLW is obtained in liquid form & the heat % is very high.

There are three ways to dispose the HLW.

With the help of Storage Tank:

- The agitator is placed, which is rotating type. In that agitator the high temperature liquid waste is kept. Due to its continuous rotation, & outer cooling, it will help to its high temperature is converted into its normal value. For the protection & leak proof purpose the closed vessel surrounded by stainless steel tank & concrete layer. Whenever the tank is full, it will be well sealed & buried underground.

Disposal through Deep Well Injection:

- In this method, first up all the high temperature liquid HLW is kept in storage tank. Then with the help of pumps these liquid HLW is sent to ground at high pressure. Its depth is normally 3500 to 16000 feet.

Vitrification Process:

- We know that, the HLW is liquid form & it is difficult to handling and disposal. To overcome this drawback in vitrification process first up all it is converted into solid form (the liquid form of HLW is converted into solid form is known as vitrification).
- Whenever the liquid HLW is kept with steel container, it is mixed with glass forming material through heating process. Due to this a solid glass is formed which is put in steel container, after that it is surrounded by reinforced concrete. These tanks are now ready for disposal.

There are two ways of disposing these solid waste tanks:

1. It can be kept in trench deep underground.
2. It can be suspended in sea beds.

Site Selection of Nuclear Power Station

Factors governing Selection of site for the nuclear power plant

Availability of water : Sufficient supply of neutral water is obvious for generating steam & cooling purposes in nuclear power station.

Disposal of Waste : The wastes of nuclear power station are radioactive and may cause severe health hazards. Because of this, special care to be taken during disposal of wastes of nuclear power plant. The wastes must be buried in sufficient

deep from earth level or these must be disposed off in sea quite away from the sea shore.

Distance from Populated Area : As there is always a probability of radioactivity, it is always preferable to locate a nuclear station sufficiently away from populated area.

Transportation Facilities : During commissioning period, heavy equipments to be erected, which to be transported from manufacturer site. So good railways and road ways availabilities are required.

Skilled Person Requirement: For availability of skilled manpower to run & handle the plant also good public transport should also be present at the site.

Near to Load Centre: As we know that generating stations are far away from thickly populated area, so to reduce the transmission & distribution losses the plant should located near to load centre.

Storage of Nuclear Material: the nuclear materials are radioactive, which are dangerous to health to overcome this drawback a separate arrangement provided for storage of material.

Geographical Condition : the radioactive material are very dangerous to human health & all living organisms, if due to earthquake chances occurs to blast the reactors to avoided this the area should be free from earthquake.

List of nuclear power stations :

Sr.No.	Place	State	Operator	Type of Reactor	Unit	Total Installed Capacity
1	Kaiga	Karnataka	NPCIL	PHWR	220 x 4	880 MW
2	Kakrapar	Gujarat	NPCIL	PHWR	220 x 2	440
3	Madras	Tamil Nadu	NPCIL	PHWR	220 x 2	440
4	Narora	Uttar Pradesh	NPCIL	PHWR	220 x 2	440
5	Rawatbhatta	Rajasthan	NPCIL	PHWR	100 x 1 200 x 1 220 x 4	1180
6	Tarapur	Maharashtra	NPCIL	PHWR BWR	540 x 2 160 x 2	1440
7	Kudankulam	Tamil Nadu	NPCIL	PHWR	1000 x 1	1000

IMPORTANT QUESTIONS:

1. Write a short note on nuclear power generation in India.
 2. Discuss various nuclear fuel which can be used for power generation.
 3. Differentiate between fissile and fertile materials.
 4. Discuss factors governing selection of site for a nuclear power plant.
 5. Write short notes on: (i) materials for control rods (ii) moderating materials.
 6. What are shielding materials?
 7. Explain the working of a nuclear power plant with a neat sketch.
 8. Compare BWR and PHWR.
 9. Discuss different types of reactors.
 10. Compare thermal and fast breeder reactors.
 11. Discuss types of coolants used in reactors.
 12. Explain the working of a BWR with a neat sketch.
 13. Explain the working of a PWR with a neat sketch.
 14. Write a brief note on Gas Cooled Reactor.
-

15. Write a short note of refuelling and type of a reactor. 16. Discuss the classification of reactors.

17. Write a short note on spent fuel disposal.

18. What is meant by emergency shutdown procedure? When is it followed?

19. Compare a nuclear power plant with a thermal power plant.

20. Compare the properties of light water and heavy water.

SHORT ANSWER TYPE QUESTIONS

1. What type of nuclear fuel is used for power generation? 2. What are different types of moderating materials used?

3. Mention three types of materials used for control rod fabrication.

4. What are various shielding materials used?

5. What is a thermal neutron?

6. Mention names of fissile and fertile materials.

7. What is the function of Calendra?

8. What is the purpose of reflector?

9. What is the difference between ionizing and non-ionizing radiation?

10. What is the biological impact of nuclear radiation?

CHAPTER: 04

DIESEL ENGINE POWER STATIONS

Diesel engine power plants are installed where supply of coal and water is not available in sufficient quantity or where power is to be generated in small quantity or where standby sets are required for continuity of supply such as in hospitals, telephone exchanges, radio stations and cinemas. These plants in the range of 2 to 50 MW. The diesel units used for electric generation are more reliable and long lived piece of equipment as compared with other types of plants.

ADVANTAGES AND DISADVANTAGES OF DIESEL ELECTRIC POWER STATION

The advantages and disadvantages of diesel power plants are list

Advantages :

1. Design and installation are very simple.
2. Can respond to varying loads without any difficulty.
3. The standby losses are less.
4. Occupy less space.
5. Can be started and put on load quickly.
6. Require less quantity of water for cooling purposes.
7. Overall capital cost is lesser than that for steam plants.
8. Require Less operating and supervising staff as compared to that for steam plants.
9. The efficiency of such plants at part loads does not fall so much as that of a steam plant.
10. The cost of building and civil engineering works is low.
10. Can burn fairly wide range of fuels.
11. These plants can be located very near to the load centres, many times in the heart of the town.
12. No problem of ash handling.
13. The lubricationsystem is more economical as compared with that of a steam power. Plant.
14. The diesel power plants are more efficient than steam power plants in the range of 150 MW capacity.

Disadvantages

1. High operating cost.
 2. High maintenance and lubrication cost.
 3. Diesel units capacity is limited. These can not be constructed in large size
 4. In a diesel power plant noise is a serious problem.
-

5. Diesel plants cannot supply overloads continuously whereas steam power plant can work under 25% overload continuously.
6. The diesel power plants are not economical where fuel has to be imported.
7. The life of a diesel power plant is quite small (2 to 5 years or less) as compared to that of steam power plant (25 to 30 years).

Different systems of diesel electric power stations:

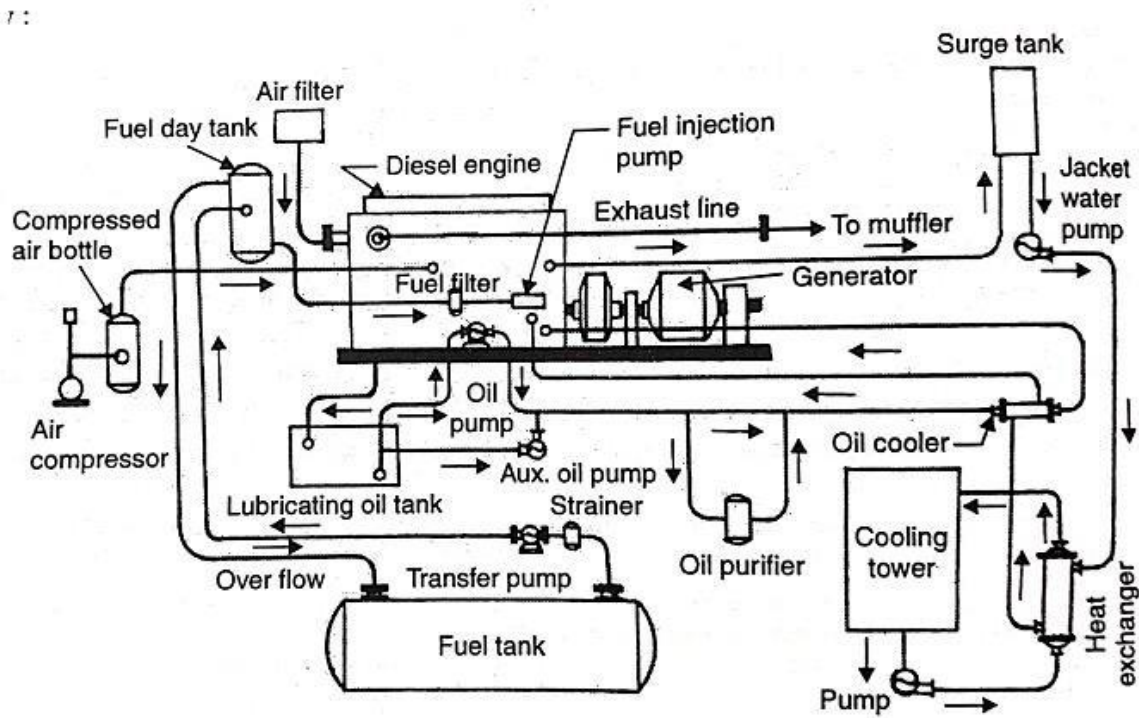

Schematic arrangement of a diesel power plant.

1. Engine
2. Air Intake system
3. Exhaust System
4. Fuel system
5. Cooling system
6. Lubrication system
7. Engine starting system
8. Governing system

1. Engine :

This is the main component of the plant which develops the required power. It is generally directly coupled to the generator .

2. Air Intake system :

The air intake system conveys fresh air through pipes or ducts to :

- (i) Air intake manifold of four stroke engines
- (ii) The scavenging pump inlet of a two stroke engine and
- (iii) The supercharger inlet of a supercharged engine.

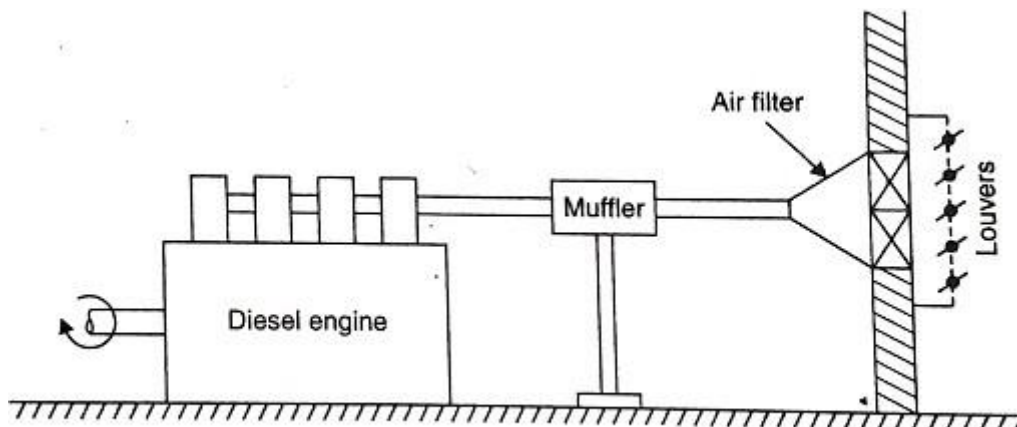

Fig. Air intake system.

The air system begins with an intake located outside the building provided with a filter to catch dirt which would otherwise cause excessive wear in the engine. The filters may be of dry or oil bath. Electrostatic precipitator filters can also be used. Oil impingement type of filter consists of a frame filled with metal shavings which are coated with a special oil so that the air in passing through the frame and being broken up into a number of small filaments comes into contact with the oil whose property is to seize and hold any dust particles being carried by the air. The dry type of filter is made of cloth, felt, glass wool etc. In case of oil bath type of filter the air is swept over or through a pool of oil so that the particles of dust become coated. Light weight steel pipe is the material for intake ducts. In some cases, the engine noise may be transmitted back through the air intake system to the outside air. In such cases a silencer is provided between the engine and the intake.

3. Exhaust System:

The purpose of the exhaust system is to discharge the engine exhaust to the atmosphere outside the building. The exhaust manifold connects the engine cylinder exhausts outlets to the exhaust pipe which is provided with a muffler to reduce pressure in the exhaust line and eliminate most of the noise which may result if gases are discharged directly into the atmosphere. The exhaust pipe leading out of the building should be short in length with minimum number of bends and should have one or two flexible tubing sections which take up the effects of expansion, and isolate the system from the engine vibration.

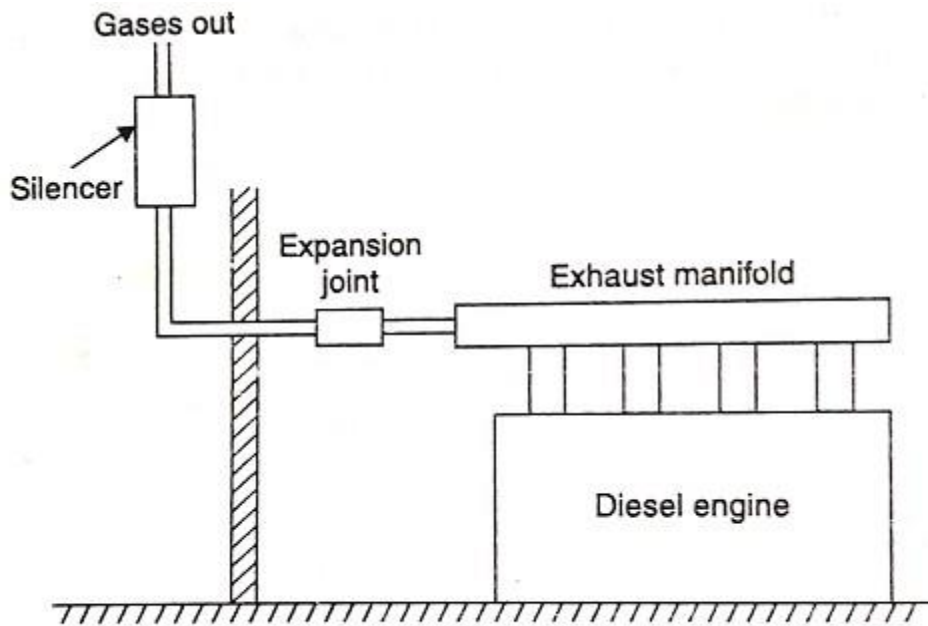

Fig. . Exhaust system.

Every engine should be provided with its independent exhaust system. The waste heat utilization in a diesel-steam station may be done by providing waste-heat boilers in which most of the heat of exhaust gases from the engine is utilised to raise low pressure steam. Such application is common on marine plants. On the stationary power plant the heat of exhaust may be utilised to heat water in gas-to-water heat exchangers consisting of a water coil placed in exhaust muffler and using the water in the plant suitably. If air heating is required, the exhaust pipe from the engine is surrounded by the cold air jacket, and transfers the heat of exhaust gases to the air.

4. Fuel System :

- The fuel oil may be delivered at the plant site by trucks, railroad tank cars or barge and tankers.
- From tank car or truck the delivery is through the unloading facility to main storage tanks and then by transfer pumps to small service storage tanks known as engine day tanks.
- Large storage capacity allows purchasing fuel when prices are low. The main flow is made workable and practical by arranging the piping equipment with the necessary heaters, by passes, shut-offs, drain lines, relief valves, strainers and filters, flow meters and temperature indicators.
- The actual flow plans depend on type of fuel, engine equipment, size of the plant etc.
- The tanks should contain manholes for internal access and repair, fill lines to receive oil, vent lines to discharge vapours, overflow return lines for controlling oil flow and a suction line to withdraw oil.
- Coils heated by hot water or steam reduce oil viscosity to lower pumping power needs.

- The minimum storage capacity of at least a month's requirement of oil should be kept in bulk, but where advantage of seasonal fluctuations in cost of oil is to be availed, it may be necessary to provide storage for a few month's requirements.
- Day tanks supply the daily fuel need of engines and , may contain a minimum of about 8 hours of oil requirement of the engines. These tanks are usually placed high so that oil may flow to engines under gravity.

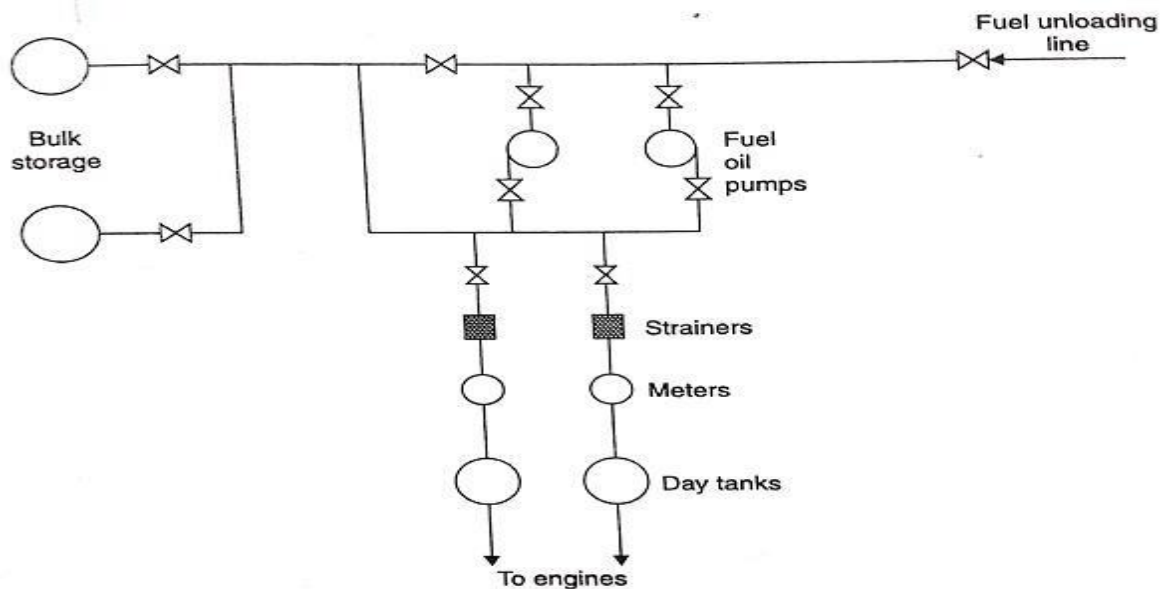

System of fuel storage for a diesel power plant.

5. Fuel Injection system:

The mechanical heart of the Diesel engine is the fuel injection system. The engine can perform no better than its fuel injection system. A very small quantity of fuel must be measured out, injected, atomised, and mixed with combustion air. The mixing problem becomes more difficult—the larger the cylinder and faster the rotative speed. Fortunately the high-speed engines are the small-bore automotive types ; however, special combustion arrangements such as pre-combustion chambers, air cells, etc. are necessary to secure good mixing. Engines driving electrical generators have lower speeds and simple combustion chambers.

6. Cooling system :

In an I.C. Engine, the temperature of the gases inside the engine cylinder may vary from 35°C or less to as high as 2750°C during the cycle. If an engine is allowed to run without external cooling, the cylinder walls, cylinder and piston will tend to assume the average temperature of the gases to which they are exposed, which may be of the order of 1000 to 1500°C. Obviously at such high temperature, the metals will lose their characteristics and piston will expand considerably and seize the liner. Of course theoretically thermal efficiency of the engine will improve without cooling but actually the engine will seize to run. If the cylinder wall temperature is allowed to rise above a certain limit, about 65°C, the lubricating oil will begin to evaporate rapidly and both cylinder and piston may be damaged. Also high temperature may cause excessive stress in some parts rendering

them useless for further operation. In view of this, part of the heat generated inside the engine cylinder is allowed to be carried away by the cooling system.

Thus cooling system is provided on an engine for the following reasons :

1. The even expansion of piston in the cylinder may result in seizure of the piston.
2. High temperatures reduce strength of piston and cylinder liner.
3. Overheated cylinder may lead to pre-ignition of the charge, in case of spark ignition engine.
4. Physical and chemical changes may occur in lubricating oil which may cause sticking of piston rings and excessive wear of cylinder.

Almost 25 to 35 per cent of total heat supplied in the fuel is removed by the cooling medium. Heat carried away by lubricating oil and heat lost by radiation amounts 3 to 5 per cent of total heat supplied. There are mainly two methods of cooling I.C. engine : 1. Air cooling 2. Liquid cooling.

7. Lubrication Systems :

Lubrication is the admittance of oil between two surface having relative motion. The purpose of lubrication may be one or more of the following :

1. To reduce friction and wear between the parts having relative motion.
2. To cool the surfaces by carrying away heat generated due to friction.
3. To seal a space adjoining the surfaces such as piston rings and cylinder liner.
4. To clean the surface by carrying away the carbon and metal particles caused by wear.
5. To absorb shock between bearings and other parts and consequently reduce noise.

The main parts of an engine which need lubrication are

- (i) Main crankshaft bearings.
- (ii) Big-end bearings.
- (iii) Small end or gudgeon pin bearings.
- (iv) Piston rings and cylinder walls.
- (v) Timing gears
- (vi) Camshaft and cam shaft bearings.
- (vii) Valve mechanism.
- (viii) Valve guides, valve tappets and rocker arms.

Various lubrication systems used for I.C. engines may be classified as :

1. Wet sump lubrication system.
 2. Dry sump lubrication system.
 3. Mist lubrication system.
-

8. Engine Starting System:

The following three are the commonly used starting systems in large and medium size engines :

1. Starting by an auxiliary engine.
2. Use of electric motors or self starters.
3. Compressed air system.

1. Starting by an auxiliary engine (generally petrol driven) : In this system an auxiliary engine is mounted close to the main engine and drives the latter through a clutch and gears. The clutch is first disengaged and the auxiliary engine started by hand or by a self starter motor. When it has warmed up and runs normally the drive gear is engaged through the clutch, and the main engine is cranked for starting. To avoid the danger of damage to drive gear it is desirable to have an over-running clutch or starter type drive.

2. Use of electric motors or self starters : These are employed for small diesel and gasoline engines. A storage battery of 12 to 36 volts is used to supply power to an electric motor which is geared to the flywheel with arrangement for automatic disengagement after the engine has started. The motor draws a heavy current and is designed to be engaged continuously for about 30 seconds only, after which it is required to cool off for a minute or so, and then re-engaged. This is done till the engine starts up. When the engine is running a small d.c. generator on the engine serves to charge the battery.

3. Compressed air system : The compressed air system is commonly used for starting large diesel engines employed for stationary power plant service. Compressed air at about 17 bar supplied from an air tank or bottle is admitted to a few of the engine cylinders making them work like reciprocating air motors to run the engine shaft. Fuel is admitted to the remaining cylinders and ignites in the normal way causing the engine to start. The air bottle or tank is charged by a motor or gasoline engine driven compressor. The system includes the following : (i) Storage tank/vessel (ii) A safety valve (iii) Interconnecting pipe work. Methods of Starting and Stopping Engines
Although starting procedure may differ from engine to engine but some common steps are listed below :

9. Governing System

The function of the governing system is to maintain the speed of the engine constant irrespective of load on the plant. This is done generally by varying the fuel supply to the engine according to the load.

Selection Of Site For The Diesel Electric Power Station

The following factors should be considered while selecting the site for a diesel power plant

1. **Foundation sub-soil condition** : The conditions of sub soil should be such that a foundation at a reasonable depth should be capable of providing a strong support to the engine.
 2. **Access to the site** : The site should be so selected that it is accessible through rail and road.
 3. **Distance from the load centre** : The location of the plant should be near the load centre. This reduces the cost of transmission lines and maintenance cost. The power loss is also minimized.
 4. **Availability of water** : Sufficient quantity of water should be available at the site selected.
 5. **Fuel Transportation** : The site selected should be near the source of fuel supply so that transportation charges are low.
-

Performance and thermal efficiency of diesel electric power station Power and Mechanical efficiency :

(I) **Indicated power** : The total power developed by combustion of fuel in the combustion chamber is called indicated power.

$$\text{I.P.} = \frac{np_{mi}LANk \times 10}{6} \text{ kW} \quad \dots(4.1)$$

where, n = Number of cylinders,
 p_{mi} = Indicated mean effective pressure, bar,
 L = Length of stroke, m,
 A = Area of piston, m^2 , and
 $k = \frac{1}{2}$ for 4-stroke engine
 $= 1$ for 2-stroke engine.

In MKS Units

$$\text{I.H.P.} = \frac{np_{mi}LANk}{4500} \quad \dots[4.1 (a)]$$

where I.H.P. = Indicated horse power,
 n = Number of cylinders,
 p_{mi} = Indicated mean effective pressure, kgf/cm^2 ,
 L = Length of stroke, m,
 A = Area of piston, cm^2 , and
 $k = \frac{1}{2}$ for 4-stroke engine
 $= 1$ for 2-stroke engine.

(ii) **Brake power (B.P.)**. The power developed by an engine at the output shaft is called the **brake power**.

$$\text{B.P.} = \frac{2\pi NT}{60 \times 1000} \text{ kW} \quad \dots(4.2)$$

where, N = Speed in r.p.m., and
 T = Torque in N-m.

In MKS Units

$$\text{B.H.P.} = \frac{2\pi NT}{4500} \quad \dots[4.2 (a)]$$

where B.H.P. = Brake horse power,
 N = Speed in r.p.m., and
 T = Torque in kgf m .

The difference between I.P. and B.P. is called **frictional power, F.P.**

i.e.,
$$F.P. = I.P. - B.P. \quad \dots(4.3)$$

 The ratio of B.P. to I.P. is called *mechanical efficiency*

i.e., *Mechanical efficiency*,
$$\eta_{\text{mech.}} = \frac{B.P.}{I.P.} \quad \dots(4.4)$$

In MKS Units	$F.H.P. = I.H.P. - B.H.P. \quad \dots[4.4 (a)]$
and	$\eta_{\text{mech.}} = \frac{B.H.P.}{I.H.P.} \quad \dots[4.4 (b)]$

2. Mean effective pressure and torque

Mean effective pressure is defined as hypothetical pressure which is thought to be acting on the piston throughout the power stroke. If it is based on I.P. it is called *indicated mean effective pressure* ($I_{\text{m.e.p.}}$ or p_{mi}) and if based on B.P. it is called *brake mean effective pressure* ($B_{\text{m.e.p.}}$ or p_{mf}). Similarly, frictional mean effective pressure ($F_{\text{m.e.p.}}$ or p_{mf}) can be defined as :

$$F_{\text{m.e.p.}} = I_{\text{m.e.p.}} - B_{\text{m.e.p.}} \quad \dots(4.5)$$

The torque and mean effective pressure are related by the engine size.

Since the power (P) of an engine is dependent on its size and speed, therefore it is not possible to compare engine on the basis of either power or torque. *Mean effective pressure is the true indication of the relative performance of different engines.*

3. Specific output

It is defined as the *brake output per unit of piston displacement* and is given by :

$$\begin{aligned} \text{Specific output} &= \frac{B.P.}{A \times L} \\ &= \text{Constant} \times p_{mb} \times \text{r.p.m.} \end{aligned} \quad \dots(4.6)$$

For the same piston displacement and brake mean effective pressure (p_{mb}) an engine running at higher speed will give more output.

4. Volumetric efficiency

It is defined as the ratio of actual volume (reduced to N.T.P.) of the charge drawn in during the suction stroke to the swept volume of the piston.

The average value of this efficiency is from 70 to 80 per cent but in case of *supercharged engine* it may be more than 100 per cent, if air at about atmospheric pressure is forced into the cylinder at a pressure greater than that of air surrounding the engine.

5. Fuel-air ratio

It is the ratio of the mass of fuel to the mass of air in the fuel-air mixture.

"Relative fuel air ratio" is defined as the ratio of the actual fuel air ratio to that of stoichiometric fuel-air ratio required to burn the fuel supplied.

6. Specific fuel consumption (s.f.c.)

It is the mass of fuel consumed per kW developed per hour, and is a criterion of economical power production.

i.e.,
$$\text{s.f.c.} = \frac{m_f}{B.P.} \text{ kg/kWh.}$$

$$\left[\begin{array}{l} \text{In MKS Units} \\ \text{s.f.c.} = \frac{m_f}{\text{B.H.P.}} \text{ kg/B.H.P.-hr where } m_f \text{ is the fuel consumed in kg/hr} \end{array} \right]$$

7. Thermal efficiency and heat balance

Thermal efficiency. It is the ratio of indicated work done to energy supplied by the fuel.

If, \dot{m}_f = Mass of fuel used in kg/sec., and
 C = Calorific value of fuel (lower),

Then indicated thermal efficiency (based on I.P.),

$$\eta_{th. (I)} = \frac{\text{I.P.}}{\dot{m}_f \times C} \quad \dots(4.7)$$

and brake thermal efficiency (based on B.P.)

$$\eta_{th. (B)} = \frac{\text{B.P.}}{\dot{m}_f \times C} \quad \dots(4.8)$$

$$\left[\begin{array}{l} \text{In MKS Units} \\ \eta_{th. (I)} = \frac{\text{I.H.P.} \times 4500}{J \times m_f \times C} \quad \dots[4.7 (a)] \\ \text{and} \\ \eta_{th. (B)} = \frac{\text{B.H.P.} \times 4500}{J \times m_f \times C} \quad \dots[4.8 (a)] \end{array} \right]$$

Heat balance sheet

The performance of an engine is generally given by heat balance sheet.

To draw a heat balance sheet for I.C. engine, it is run at constant load. Indicator diagram is obtained with the help of an indicator. The quantity of fuel used in a given time and its calorific value, the amount, inlet and outlet temperature of cooling water and the weight of exhaust gases are recorded. After calculating I.P. (or I.H.P.) and B.P. (or B.H.P.), the heat in different items is found as follows :

Heat supplied by fuel :

For petrol and oil engines, heat supplied = $m_f \times C$, where m_f and C are mass used per minute (kg) and lower calorific value (kJ or kcal) of the fuel respectively.

For gas engines, heat supplied = $V \times C$, where V and C is volume at N.T.P. ($\text{m}^3/\text{min.}$) and lower calorific value of gas respectively.

(i) Heat absorbed in I.P.

Heat equivalent of I.P. (per minute) = I.P. \times 60 kJ ...(4.9)

$$\left[\begin{array}{l} \text{In MKS units} \\ \text{Heat equivalent of I.H.P. (per minute)} = \frac{\text{I.H.P.} \times 4500}{J} \text{ kcal} \quad \dots[4.9 (a)] \end{array} \right]$$

(ii) Heat taken away by cooling water

If, m_w = Mass of cooling water used per minute,
 t_1 = Initial temperature of cooling water,
 t_2 = Final temperature of cooling water,

Then, heat taken away by water = $m_w \times c_{pw} \times (t_2 - t_1)$...(4.10)

where c_{pw} = Specific heat of water.

(iii) **Heat taken away by exhaust gases**

If, m_e = Mass of exhaust gases (kg/min),

c_{pg} = Mean specific heat at constant pressure,

t_e = Temperature of exhaust gases,

t_r = Room (or boiler house) temperature,

Then, heat carried away by exhaust gases = $m_e \times c_{pg}(t_e - t_r)$ (4.11)

Note. The mass of exhaust gases can be obtained by adding together mass of fuel supplied and mass of air supplied.

The *heat balance sheet* from the above data can be drawn as follows :

Item	kJ	Percent
Heat supplied by fuel
(i) Heat absorbed in I.P. (or I.H.P.)
(ii) Heat taken away by cooling water
(iii) Heat carried away by exhaust gases
(iv) Heat unaccounted for (by difference)
Total

8. Exhaust smoke and other emissions

Smoke is an indication of incomplete combustion. It limits the output of an engine if air pollution control is the consideration. *Exhaust emissions* have of late become a matter of grave concern and with the enforcement of legislation on air pollution in many countries, it has become necessary to view them as performance parameters.

9. Specific weight

It is defined as the weight of the engine in kg for each B.H.P. developed. It is an indication of the engine bulk.

POSSIBLE QUESTIONS

1. Discuss relative merits and demerits of diesel engine plant.
 2. Explain the classification of diesel engines.
 3. Compare low speed and high speed diesel engines.
 4. Enumerate the advantages of turbo charged engines over naturally aspirated engines.
 5. Discuss types of liquid fuels which can be used in diesel engines.
 6. Write a brief note on gas engines.
 7. Explain the construction and working of a diesel engine power plant.
 8. Draw the plant layout of a 2,000 kVA, 400 V, 50 Hz diesel plant.
 9. Write maintenance schedule of a diesel engine power plant.
 10. Explain with a neat sketch, the heat recovery system employing DG set.
 11. How does the ambient temperature and altitude affect the output of diesel power plant?
 12. Write a brief note on sizing of DG set.
-

13. What are the factors which affect the height of stack in a diesel power plant?
14. Discuss factors affecting selection of a diesel power plant.
15. Give a brief note on energy balance in a diesel power plant.
16. Compare relative merits and demerits of a diesel and gas turbine power plants.

SHORT ANSWER TYPE QUESTIONS

1. Write three fuels which can be used in diesel engine.
 2. Differentiate between marine diesel engine and diesel engines used for power generation.
 3. How does speed of engine affects its size?
 4. Why low speed engines are preferred for continuous power generation?
 5. What is the purpose of injectors in diesel engine?
 6. What type of alternator is used in diesel engine power plant?
 7. What is the range of efficiency of diesel engine?
-

CHAPTER : 05

HYDEL POWER STATION

In hydro-electric plants energy of water is utilised to move the turbines which in turn run the electric generators. The energy of water utilised for power generation may be kinetic or potential. First hydro-electric station was probably started in America in 1882 and thereafter development took place very rapidly. In India the first major hydro-electric development of 4.5 MW capacity named as Sivasamudram Scheme in Mysore was commissioned in 1902. Hydro (water) power is a conventional renewable source of energy which is clean, free from pollution and generally has a good environmental effect.

Advantages and Disadvantages of Hydroelectric Power Plant :

Advantages of hydro-electric plant :

1. No fuel charges.
2. An hydro-electric plant is highly reliable.
3. Maintenance and operation charges are very low.
4. Running cost of the plant is low.
5. The plant has no stand by losses.
6. The plant efficiency does not change with age.
7. It takes a few minutes to run and synchronise the plant.
8. Less supervising staff is required.
9. No fuel transportation problem.
10. No ash problem and atmosphere is not polluted since no smoke is produced in the plant.
11. In addition to power generation these plants are also used for flood control and irrigation purposes.
12. Such a plant has comparatively a long life (100-125 years as against 20-45 years of a thermal plant).
13. The number of operations required is considerably small compared with thermal power plants.
14. The machines used in hydro-electric plants are more robust and generally run at low speeds at 300 to 400 r.p.m. where the machines used in thermal plants run at a speed 3000 to 4000 r.p.m. Therefore, there are no specialised mechanical problems or special alloys required for construction.
15. The cost of land is not a major problem since the hydro-electric stations are Situated away from the developed areas.

Disadvantages :

1. The initial cost of the plant is very high.
-

2. It takes considerable long time for the erection of such plants.
3. Such plants are usually located in hilly areas far away from the load centre and as such they require long transmission lines to deliver power, subsequently the cost of transmission lines and losses in them will be more.

Power generation by the hydro-electric plant is only dependent on the quantity of Water available which in turn depends on the natural phenomenon of rain. So if the rainfall is in time and proper and the required amount of can be collected, the plant will function satis-factorily otherwise not.

Classification Of Hydro-Electric Power Plants

Hydro-electric power stations may be classified as follows :

A. According to availability of head

1. High head power plants
2. Medium head power plants
3. Low head power plants

B. According to the nature of load

1. Base load plants
2. Peak load plants

C. Accordingly to the quantity of water available

1. Run-of-river plant without pondage
2. Run-of-river plant with pondage
3. Storage type plants
4. Pump storage plants
5. Mini and micro-hydel plants

A. According to availability of head

The following figures give a rough idea of the heads under which the various types of plants Work

- High head power plants - 100m and above
- Medium head power plants - 20 to 500m
- Low head power plants - 25 to 80m

Note. It may be noted that figures given above overlap each other. Therefore it is difficult to classify plant directly on the basis of head alone. The basis, therefore, technically adopted turbine used for a particular plant.

High Head Power Plants

These types of plants work under heads 100 in and above. Water is usually stored up in lakes on high mountains during the rainy season or during the season when the snow melts. The rate of flow should be such that water can last throughout the year. Surplus water discharged by the spillway can not endanger the stability of the main dam by erosion because they are separated. The tunnel through the mountain has a surge chamber excavated near the exit. Flow is controlled by head gates at the-tunnel intake, butterfly valves at the top of the penstocks, and gate valves at the turbines. This type of site might also be suitable for an underground station.

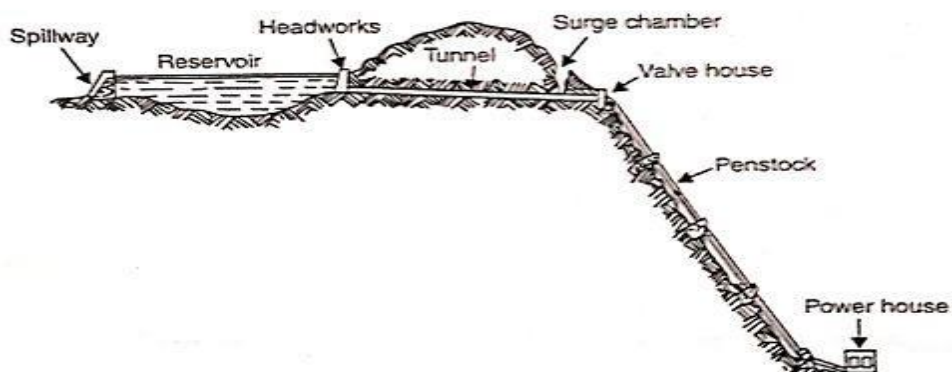

Medium Head Power Plants :

When the operating head of water lies between 30 to 100 metres, the power plant is known as medium head power plant. This type of plant commonly uses Francis turbine. The forebay provided at the beginning of the penstock serves as water reservoir. In such plants, the water is generally carried in open canals from main reservoir to the forebay and then to the powerhouses through the penstock. The forebay itself works as a surge tank in this plant.

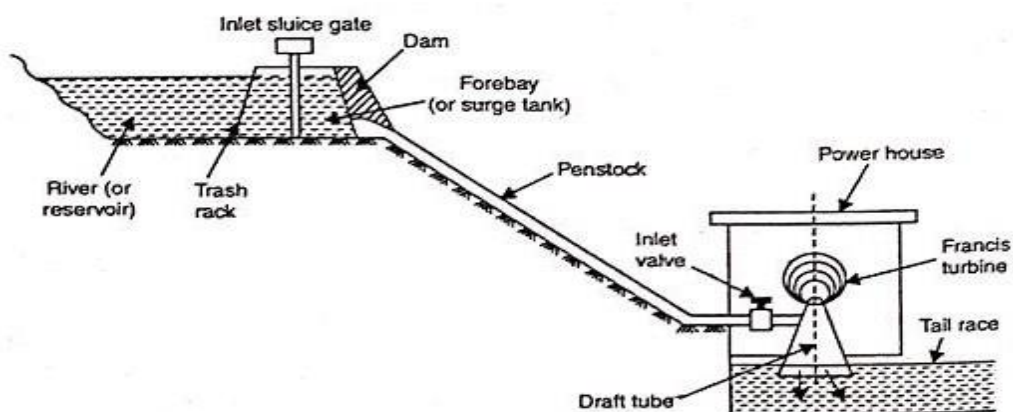

. Medium head power plant layout.

Low head power plant :

These plants usually consists of a dam across a river. A sideway stream diverges from the river at the dam. Over this stream the power house is constructed. Later this channel joins the river further downstream. This type of plant uses vertical shaft Francis turbine or Kaplan turbine.

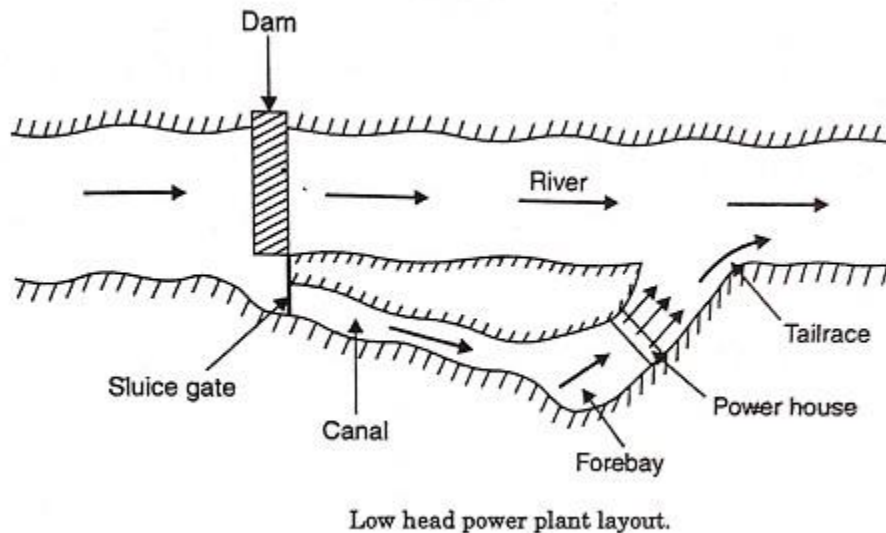

Base Load Plants

The plants which cater for the base load of the system are called base load plants. These plants are required to supply a constant power when connected to the grid. Thus they run without stop and are often remote-controlled with which least staff is required for such plants. Run-of-river plants without pondage may sometimes work as baseload plant, but the firm capacity in such cases, will be muchless.

Peak Load Plants

The plants which can supply the power during peak loads are known as peak load plants. Some me of such plants supply the power during average load but also supply peak load as and when it is there. Whereas other peak load plants are required to work during peak load hours only. The run-of-river plants may be made for the peak-load by providing pondage.

C. According to the quantity of water available

Run-of-river Plants without Pondage

A run-of-river plant without pondage, as the name indicates, does not store water and uses water as it comes. There is no control on flow of water so that during high floods or low loads water is wasted while during during low run-off the plant capacity is considerably reduced. Due to non uniformity of supply and lack of assistance from a firm capacity the utility of these plants is much less than those of other types. The head on which these plants work varies considerably. Such a

plant can be made a great deal more useful by providing sufficient storage at the plant to take care of the 'hourly fluctuations in load. This lends some firm capacity to the plant. During good flow conditions these plants may cater to base load of the system, when flow reduces they may supply the peak demands. Head water elevation for plant fluctuates with the flow conditions. These plants without storage may sometimes be made to supply the base load, but the firm capacity depends on the minimum flow of river. The run-of-river plant may be made for load service with pondage, though storage is usually seasonal.

Run-of-river Plant with Pondage

Pondage usually refers to the collection of water behind a dam at the plant and increases the stream capacity for a short period, say a week. Storage means collection of water in up stream reservoirs and this increases the capacity of the stream over an extended period of several months. Storage plants may work satisfactorily as base load and peak load plants. This type of plant, as compared to that without pondage, is more reliable and its generating capacity is less dependent on the flow rates of water available.

Storage Type Plants

A storage type plant is one with a reservoir of sufficiently large size to permit carry-over storage from the wet season to the dry season, and thus to supply firm flow substantially more than the minimum natural flow. This plant can be used as base load plant as well as peak load plant as water is available with control as required. The majority of hydro-electric plants are of this type.

Pumped Storage Plants

Pumped storage plant. Pumped storage plants are employed at the places where the quantity of water available for power generation is inadequate. Here the water passing through the turbines is stored in 'tail race pond'. During low load periods this water is pumped back to the head reservoir using the extra energy available.

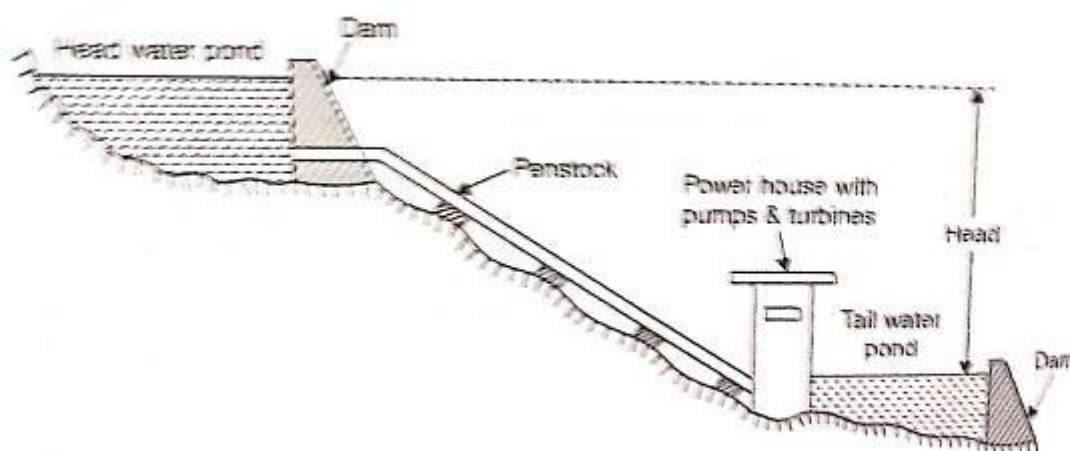

1. Pumped storage plant.

This water can be again used for generating power during peak load periods. Pumping of water may be done seasonally or daily depending upon the conditions of the site and the nature of the load on the plant. Such plants are usually interconnected with steam or diesel engine plants so that off peak capacity of interconnecting stations is used in pumping water and the same is used during peak load periods. Of course, the energy available from the quantity of water pumped by the plant is less than the energy input during pumped operation. Again while using pumped water the power available is reduced on account of losses occurring in primemovers.

Mini and Micro Hydel Plants

In order to meet with the present energy crisis partly, a solution is to develop mini (5 m to 20m head) and micro (less than 5 in head) hydel potential in our country. The low head hydro-potential is scattered in this country and estimated potential from such sites could be as much as 20,000 MW. By proper planning and implementation, it is possible to commission a small hydro-generating set up of 5 MW with a period of one and half year against the period of a decade or two for large capacity power plants. Several such sets upto 1000 kW each have been already installed in Himachal Pradesh, U.P., Arunachal Pradesh, West Bengal and Bhutan.

Selection Of Site For A Hydro-Electric Plant

The following factors should be considered while selecting the site for a hydro-electric plant:

1. Availability of water
2. Water storage
3. Water head
4. Accessibility of the site
5. Distance from load centre
6. Type of the land of site.

1. Availability of water :

The most important aspect of hydro-electric plant is the availability of water at the site since all other designs are based on it. Therefore the run-off data at the proposed site must be available before hand. It may not be possible to have run-off data at the proposed site but data concerning the rainfall over the large catchment area is always available. Estimate should be made about the average quantity of water available throughout the year and also about maximum and minimum quantity of water available during the year. These details are necessary to : (i) decide the capacity of the hydro-electric plant, (ii) setting up of peak load plant such as steam, diesel or gas turbine plant and to, (iii) provide adequate spillways or gate relief during the flood period.

2. Water storage :

Since there is a wide variation in rainfall during the year, therefore, it is always necessary to store the water for continuous generation of power. The storage capacity can be calculated with the help of mass curve. Maximum storage should justify the expenditure on the project.

The two types of storages in use are :

- (i) The storage is so constructed that it can make water available for power generation of one year only. In this case storage becomes full in the beginning of the year and becomes empty at the end of each year.
- (ii) The storage is so constructed that water is available in sufficient quantity even during the worst dry periods.

3. Water head:

In order to generate a requisite quantity of power it is necessary that a large quantity of water at a sufficient head should be available. An increase in effective head, for a given output, reduces the quantity of water required to be supplied to the turbines.

4. Accessibility of the site:

The site where hydro-electric plant is to be constructed should be easily accessible. This is important if the electric power generated is to be utilised at or near the plant site. The site selected should have transportation facilities of rail and road.

5. Distance from the load centre:

It is of paramount importance that the power plant should be set up near the load centre; this will reduce the cost of erection and maintenance of transmission line

6. Type of the land of the site:

The land to be selected for the site should be cheap and rocky. The ideal site will be one where the dam will have largest catchment area to store water at high head and will be economical in construction. The necessary requirements of the foundation rocks for a masonry dam are as follows:

- (i) The rock should be strong enough to withstand the stresses transmitted from the dam structure as well as the thrust of the water when the reservoir is full.
 - (ii) The rock in the foundation of the dam should be reasonably impervious.
 - (iii) The rock should remain stable under all conditions.
-

List of Hydroelectric Power Plants in India

States	River and Capacity	Hydroelectric Power Plant
Andhra Pradesh	1000	Nagarjunasagar Hydro Electric Power plant
Andhra Pradesh	600	Srisailem Hydro Electric Power plant
Andhra Pradesh, Orissa	114	Machkund Hydro Electric Power plant
Gujarat	300	Sardar Sarovar Hydro Electric Power plant
Himachal Pradesh	200	Baira-Siul Hydroelectric Power plant
Himachal Pradesh	Sutlej	Bhakra Nangal Hydroelectric Power plant
Himachal Pradesh	Beas	Dehar Hydroelectric Power plant
Himachal Pradesh	Sutlej	Nathpa Jhakri Hydroelectric Power plant
Jammu and Kashmir	270	Salal Hydro Electric Power plant
Jammu and Kashmir	Jhelum	Uri Hydro Electric Power plant
Jharkhand	Subarnarekha	Subarnarekha Hydroelectric Power plant
Karnataka	396	Kalinadi Hydro Electric Power plant
Karnataka	800	Sharavathi Hydroelectric Power plant
Karnataka	Kaveri	Shivanasamudra Hydroelectric Power plant
Kerala	390	Idukki Hydro Electric Power plant
Madhya Pradesh	Sone	Bansagar Hydroelectric Power plant
Madhya Pradesh	Narmada	Indira Sagar Hydro Electric Power plant
Madhya Pradesh, Uttar Pradesh	Rihand	Rihand Hydroelectric Power plant
Maharashtra	860	Koyna Hydroelectric Power plant
Manipur	70	Loktak Hydro Electric Power plant
Odisha	480	Balimela Hydro Electric Power plant
Odisha	270	Hirakud Hydro Electric Power plant
Sikkim	Rangit	Rangit Hydroelectric Power plant
Sikkim	Teesta	Teesta Hydro Electric Power plant
Uttarakhand	Bhagirathi	Tehri Hydro Electric Power plant
Himachal Pradesh	Baspa	Baspa-II Hydro Electric Power plant
Himachal Pradesh	Satluj	Nathpa Jhakri Hydro Electric Power Plant
Himachal Pradesh	Beas	Pandoh Dam
Himachal Pradesh	Ravi	Chamera-I
Himachal Pradesh	Ravi	Chamera-II
Himachal Pradesh	Beas	Pong
Jammu and Kashmir	Chenab	Dulhasti

Classification of Hydraulic Turbines

- The hydraulic turbines are classified as follows :
- According to the head and quantity of water available.
- According to the name of the originator.
- According to the action of water on the moving blades.
- According to the direction of flow of water in the runner
- According to the disposition of the turbine shaft.
- According to the specific speed N_s .

According to the head and quantity of water available :

- Impulse turbine—requires high head and small quantity of flow.
- Reaction turbine—requires low head and high rate of flow.

Actually there are two types of reaction turbines, one for medium head and medium flow and the other for low head and large flow.

According to direction of flow of water in the runner :

- Tangential flow turbine (Pelton turbine)
- Radial flow turbine (no more used)
- Axial flow turbine (Kaplan turbine)
- Mixed (radial and axial) flow turbine (Francis turbine)

Impulse Turbines

The Pelton wheel or Pelton turbine is a tangential flow impulse turbine. It consists of a rotor, at the periphery of which are mounted equally spaced double-hemispherical or double-ellipsoidal buckets. Water is transferred from a high head source through penstock pipes. A branch pipe from each penstock pipe ends in a nozzle, through which the water flows out as a high speed jet. A needle or spear moving inside the nozzle controls the water flow through the nozzle and at the same time, provides a smooth flow with negligible energy loss. All the available potential energy is thus converted into kinetic energy before the jet strikes the buckets. The pressure all over the wheel is constant and equal to atmosphere, so that energy transfer occurs due to purely impulse action.

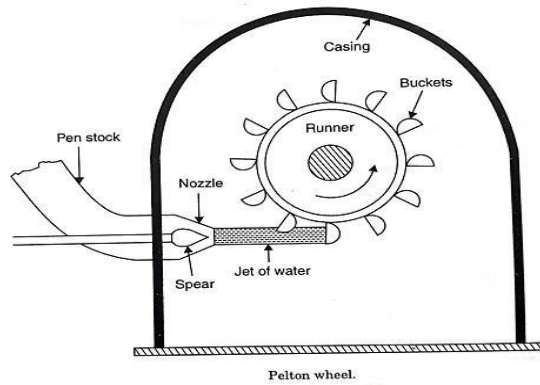

Reaction turbines

In reaction turbines, the runner utilizes both potential and kinetic energies. As the water flows through the stationary parts of the turbine, whole of its pressure energy is not transferred to kinetic energy and when the water flows through the moving parts, there is a change both in the pressure and in the direction and velocity of flow of water. As the water gives up its energy to the runner, both its pressure and absolute velocity get reduced. The water which acts on the runner blades is under a pressure above atmospheric and the runner passages are always completely filled with water.

Francis turbines

The modern Francis water turbine is an inward mixed flow reaction turbine i.e. the water under pressure, enters the runner from the guide vanes towards the centre in radial direction and discharges out of the runner axially. The Francis turbine operates under medium heads and also requires medium quantity of water. It is employed in the medium head power plants. This type of turbine covers a wide range of heads. Water is brought down to the turbine and directed to a number of stationary orifices fixed all around the circumference of the runner. These stationary orifices are commonly termed as guide vanes or wicket gates.

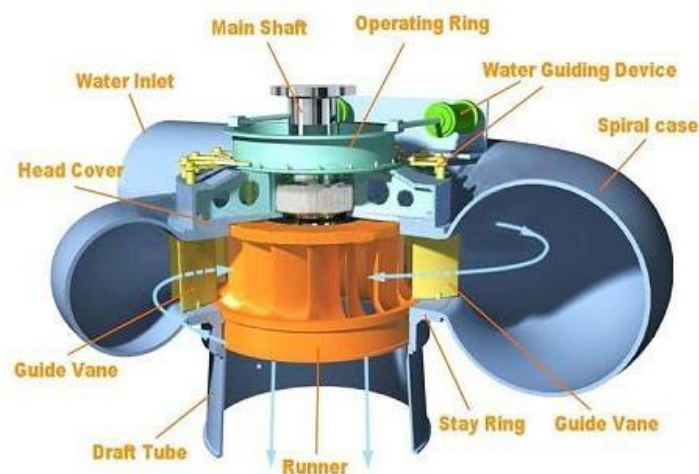

Francis Turbine

Example 3.1. A hydro power plant receives water from a reservoir of capacity 4×10^5 cubic meter at a height of 100 m. Calculate energy available in kWh. Assume overall efficiency as 80% one cubic meter of water weighs 1,000 kg.

Sol. Weight of water = Density \times Volume = $1,000 \times 4 \times 10^5$
 $= 4 \times 10^8 \text{ kgm} \Rightarrow 9.81 \times 4 \times 10^8 \text{ Newton}$

Energy available = W.H. $\eta_{\text{overall}} = \frac{(9.81 \times 4 \times 10^8) \cdot 100 \cdot 0.80}{3,600 \times 1,000}$

$= 0.872 \times 10^5 \text{ kWh}$ **Ans.**

Example 3.2. A hydro power plant has a load factor of 25% as peak load plant. Capacity of generator, head and overall efficiency are 15 MW, 40 m and 0.85 respectively. Calculate minimum flow of water so as to operate plant as base load plant.

Sol. Total units generated at 25% load factor, when operating as peak load plant

$= 15 \times 10^3 \times 0.25 \text{ kWh}$

for one week this becomes $= 15 \times 10^3 \times 0.25 \times 168 \text{ kWh}$

Let Q be the minimum flow of water required to operate the plant as base load plant.

Power developed, $P = 9.81 \times Q \times H \times \eta$
 $= 9.81 \times Q \times 40 \times 0.85$

$P = 333.54 \times Q \text{ kW}$

Total units generated per week = $333.54 \times Q \times 168 \text{ kWh}$

$\therefore 333.54 \times Q \times 168 = 15 \times 10^3 \times 0.25 \times 168$

$\Rightarrow Q = 11.24 \text{ m}^3/\text{sec.}$ **Ans.**

Example 3.3. A hydro power plant has catchment area of $1,000 \text{ km}^2$ and operates at a mean head of 205 m . The average annual rainfall is 125 cm . 80% of the rainfall is available for power generation. Load factor of plant is 75% , turbine and generator efficiencies are 90% and 95% respectively. Assuming a head loss of 5 m , determine capacity of power plant.

Sol. Catchment area = $1,000 \text{ km}^2 = 1,000 \times 10^6 \text{ m}^2$

Average annual rainfall = $125 \text{ cm} = 1.25 \text{ m}$, yield factor = 80%

Volume of water available for utilisation per annum

$$V = \text{Catchment area} \times \text{Average annual rainfall} \times \text{Yield factor} \\ = 1,000 \times 10^6 \times 1.25 \times 0.8 = 1,000 \times 10^6 \text{ m}^3/\text{annum}$$

Volume of water available per second

$$= \frac{1,000 \times 10^6}{8,760 \times 60 \times 60} = 31.71 \text{ m}^3/\text{s}$$

Net water head available = Gross head – Head loss

$$= 205 - 5 = 200 \text{ m}$$

Overall plant efficiency, $\eta = \eta_{\text{turbine}} \times \eta_{\text{generator}}$

$$= 0.90 \times 0.95 = 0.855$$

Average power generated, $P = \text{Volume of water} \times \text{head} \times \eta \times 10^{-6} \text{ MW}$

$$= 1000 \times 31.71 \times 200 \times 0.855 \times 10^{-6} \\ = 53.2 \text{ MW}$$

Assuming a load factor of 75% , plant capacity = $\frac{53.2}{0.75} = 70.9 \text{ MW}$

Ans.

POSSIBLE QUESTIONS

1. Discuss advantages and disadvantages of hydro power plant.
 2. What are various factors which govern the selection of site for a hydro power plant.
 3. Explain the construction and working of a hydro electric power plant with a neat sketch.
 4. Discuss the working of a pumped storage plant with a neat sketch.
 5. What is small hydro power plant?
 6. Describe the function of (i) trash rack, (ii) surge tank, (iii) draft tube, (iv) spillways.
 7. What is siltation? How does it affect the power output of a plant?
 8. Write a brief note on cavitation.
 9. Why cavitation does not take place in impulse turbine?
 10. Write a brief note on different types of dams used for a hydro electric power plant.
 11. Discuss various types of turbines used in a hydro power plant.
-

12. Compare Pelton wheel, Francis turbine and Kaplan turbine.
13. Explain the importance of specific speed in design of hydro turbines.
14. Write a brief note on characteristics of hydro turbine.

SHORT ANSWER TYPE QUESTIONS

1. Why draft tube is needed at the tail race?
 2. What is the purpose of spillways?
 3. What is hydrological cycle?
 4. What is the difference between a storage dam and a diversion dam?
 5. Write two types of reaction hydro turbines.
 6. Write two types of impulse hydro turbines.
 7. What is hydrological cycle?
 8. What is water hammer?
 9. What is a micro hydel plant?
 10. What is the function of guide vanes?
-

CHAPTER-06

GAS TURBINE POWER STATION

Gas turbine power plant uses natural gas obtained from petroleum wells. The gas contains mainly methane and higher hydrocarbons. This gas is burnt in a gas turbine to generate hot flue gases which drives the turbine.

Selection of site for gas turbine station :

While selecting the site for a gas turbine plant. The following points should be given due consideration :

1. The plant should be located near the load centre to avoid transmission costs and losses.
2. The site should be away from business centres due to noisy operations.
3. Cheap and good quality fuel should be easily available.
4. Availability of labour.
5. Availability of means of transportation.
6. The land should be available at a cheap price.
7. The bearing capacity of the land should be high.

Fuels for Gas turbine :

The various fuels used in gas turbines are enumerated and discussed as follows :

- Gaseous fuels
- Liquid fuels
- Solid fuels.

1 . Gaseous fuels.

Natural gas is the ideal fuel for gas turbines, but this is not available everywhere. Blast furnace gas and producer gas may also be used for gas turbine power plants.

2 . Liquid fuels.

- Liquid fuels of petroleum origin such as distillate oils or residual oils are most commonly used for gas turbine plant.
 - The essential qualities of these fuels include proper volatility, viscosity and calorific value.
 - At the same time it should be free from any contents of moisture and suspended impurities that would clog the small passages of the nozzles and damage valves and plungers of the fuel pumps.
-

- Minerals like sodium, vanadium and calcium prove very harmful for the turbine blading as these build deposits or corrode the blades. The sodium in ash should be less than 30% of the vanadium content as otherwise the ratio tends to be critical.
- The actual sodium content may be between 5 ppm to 10 ppm (part per million). If the vanadium is over 2 ppm, the magnesium in ash tends to become critical. It is necessary that the magnesium in ash is least three times the quantity of vanadium. The content of calcium and lead should not be over 10 ppm and 5 ppm respectively. Sodium is removed from residual oils by mixing with 5% of water and then double centrifuging when sodium leaves with water.
- Magnesium is added to the washed oil in the form of epsom salts, before the oil is sent into the combustor. This checks the corrosive action of vanadium. Residual oils burn with less ease than distillate oils and the latter are often used to start the unit from cold, after which the residual oils are fed in the combustor. In cold conditions residual oils need to be preheated.

3. Solid fuels

- The use of solid fuels such as coal in pulverised form in gas turbines present several difficulties most of which have been only partially overcome yet.
 - The pulverising plant for coal in gas turbine applications is much lighter and smaller than its counterpart in steam generators.
 - Introduction of fuel in the combustion chamber of a gas turbine is required to be done against a high pressure whereas the pressure in the furnace of a steam plant is atmospheric. Furthermore, the degree of completeness of combustion in gas turbine applications has to be very high as otherwise soot and dust in gas would deposit on the turbine blading.
 - Some practical applications of solid fuel burning in turbine combustors have been commercially made available in recent years. In one such design finely crushed coal is used instead of pulverized fuel. This fuel is carried in steam of air tangentially into one end of a cylindrical furnace while gas comes out at the centre of opposite end.
 - As the fuel particles roll around the circumference of the furnace they are burnt and a high temperature of about 1650°C is maintained which causes the mineral matter of fuel to be converted into a liquid slag. The slag covers the walls of the furnace and runs out through a top hole in the bottom.
 - The result is that fly ash is reduced to a Very small content in the gases. In another design a regenerator is used to transfer the heat to air, the combustion chamber being located on the outlet of the turbine, and the combustion is carried out in the turbine exhaust stream. The advantage is that only clean air is handled by the turbine.
-

Elements Of Simple Gas Turbine Power Plant

The main components of a gas turbine power plant are enumerated and discussed as follows :

1. Gas turbines
2. Compressors
3. Combustor
4. Intercoolers and regenerators.

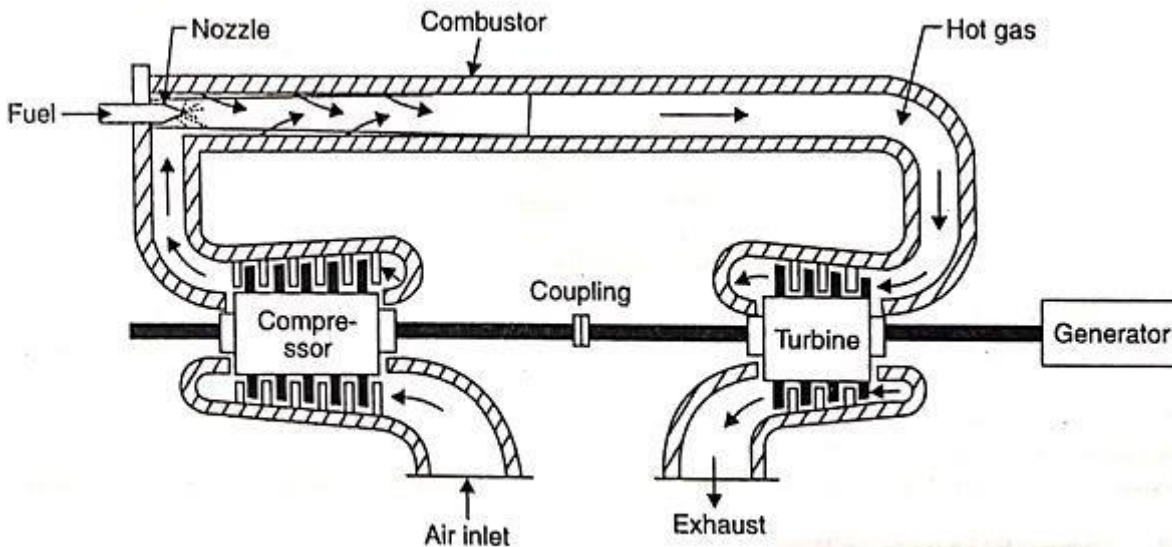

Arrangement of a simple gas turbine plane.

1. Gas turbines :

A turbine basically employs vanes or blades mounted on a shaft and enclosed in a casing. The flow of fluid through the turbine in most design is axial and tangential to the rotor at a nearly constant or increasing radius. The basic requirements of the turbines are :

- I. Light weight
- II. (ii) High efficiency
- III. (iii) Reliability in operation and
- IV. (iv) Long working life.

Large work output can be obtained per stage with high blade speeds when the blades are designed to sustain higher stresses. More stages of the turbine are always preferred in gas turbine power plant because it helps to reduce the stresses in the blades and increases the overall life of the turbine. It is essential to cool the gas turbine blades for long life as these are continuously subjected to high temperature gases. The blades can be cooled by different methods, the common method being the air-cooling. The air is passed through the holes provided through the blade.

The following accessories are fitted to the turbine :

(i) Tachometer : It shows the speed of the machine and also actuates the fuel regulator in case the speed shoots above or falls below the regulated speed, so that the fuel regulator admits less or more fuel into the combustor and varies the turbine according to the demand. The tachometer is driven through a gear box.

(ii) An overspeed governor. The governor backs off fuel feed if exhaust temperature from the turbine exceeds the safe limit, thermal switches at the turbine exhaust acting on fuel control to maintain present maximum temperature.

(iii) Lubricating oil pump : It supplies oil to the bearings under pressure.

(iv) Starting motor or engine

(v) Starting set-up gear

(vi) Oil coolers

(vii) Filters

(viii) Inlet and exhaust mufflers.

2. Compressors :

The compressors which are commonly used are of the following two types :

- Centrifugal type
- Axial flow type

The 'centrifugal compressor' consists of an impeller and a diffuser. The impeller imparts the high kinetic energy to the air and diffuser converts the kinetic energy into the pressure energy. The pressure ratio of 2 to 3 is possible with single stage compressor and it can be increased upto 20 with 3-stage compressor.

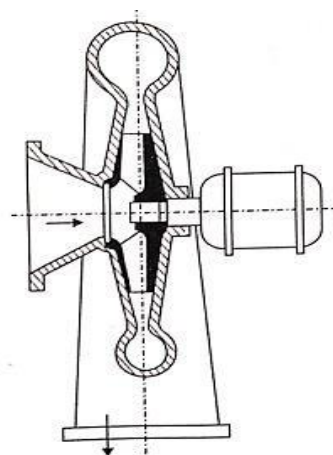

Single stage centrifugal compressor.

An axial compressor is capable of delivering constant volumes of air over varying discharge pressures. These machines are well suited for large capacities at moderate pressures. If the impeller of a centrifugal compressor is designed to give an axial component of velocity at the exit, the design becomes a mixed flow type.

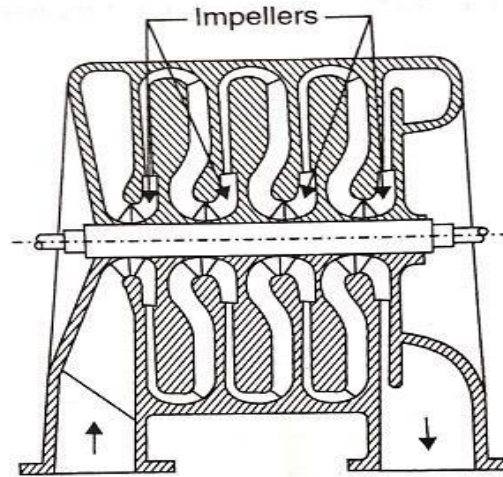

Multistage single flow axial compressor.

3. Combustor :

The primary function of the combustor is to provide for the chemical reaction of the fuel and air being supplied by the compressor.

The physical process of combustion may be divided into four important steps :

- Formation of reactive mixture
- Ignition
- Flame propagation
- Cooling of combustion products with air.

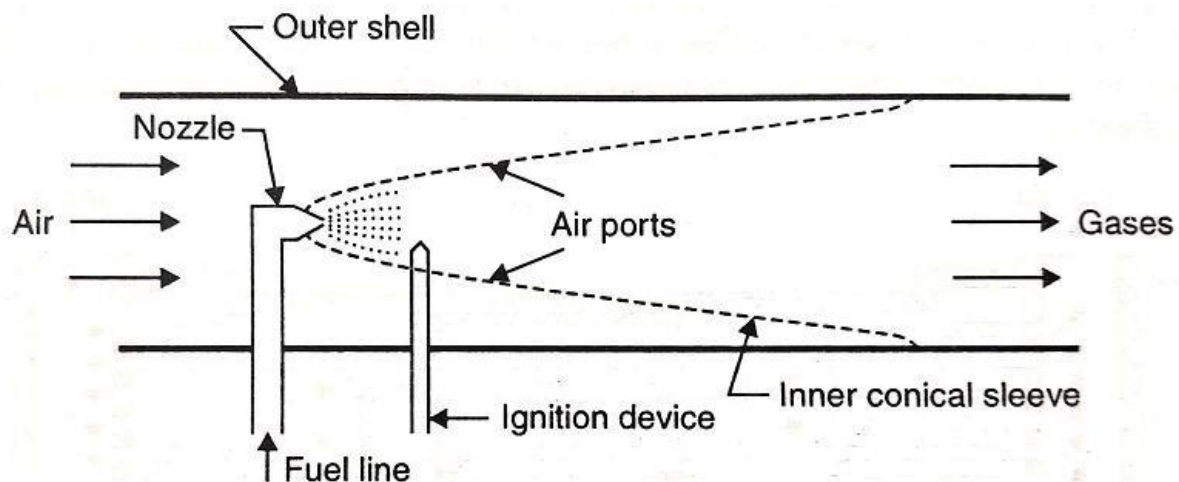

Arrangement of a combustor.

Figure shows an arrangement of a typical combustor design which employs an outer cylindrical shell with a conical inner sleeve which is provided with ports or slots along the length. At the cone apex is fitted a nozzle through which fuel is sprayed in a conical pattern into the sleeve. Near this is an igniting device or spark plug. A fuel line conveys the fuel to the nozzle. A few air ports are provided close to the situation of the nozzle supply the combustion air directly to the fuel and are fitted with vanes to produce a whirling motion of oil and thereby create turbulence. The rest of air admitted ahead of combustion zone serves to cool the combustor and outlet gases. The combustor is best located between the compressor outlet and turbine inlet and takes the shape of a cylinder. Alternatively, the 'can' arrangement may be used in which the flow is divided to pass through number of smaller cylindrical chambers. In this latter design the adjacent chambers may be interconnected through small tubes so that a simple igniting device fitted in one of the chambers serves all the chambers. The nozzle sprays the fuel under pressure in an atomised conical spray. The fuel is delivered to the nozzle through the fuel line and flows out through a whirling motion in an annular chamber from where it passes out through a small orifice in then conical pattern of desired angle.

4. Intercoolers and regenerators :

In a gas turbine plant the intercooler is generally used when the pressure ratio used is sufficiently large and the compression is completed with two or more stages. The cooling of compressed air is generally done with the use of cooling water. A cross-flow type intercooler is generally preferred for effective heat transfer.

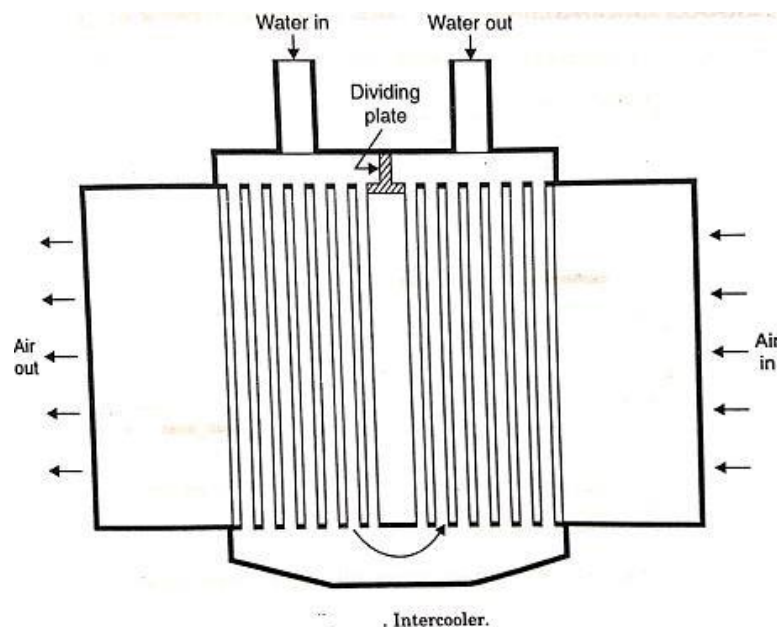

Regenerators.

In the regenerator heat transfer takes place between the exhaust gases and cool air. It is usually made in shell and tube construction with gas flowing inside the tubes and air outside the tubes, the two fluids being made to flow in opposite directions. Since the gas is bound to carry dust and deposit the same on the heat transfer surface, the internal flow through the tubes is convenient as the tube inside can be easily cleaned with brushes whereas it is very difficult to clean the outside surface of tubes. The effect of counterflow is the highest average temperature difference between the heating and heated medium with consequent high heat transfer between the two fluids. A number of baffles in the air put in the shell make the air to flow in contact with maximum heat transfer. However, the pressure drop in both air and gas during the flow should be minimum possible.

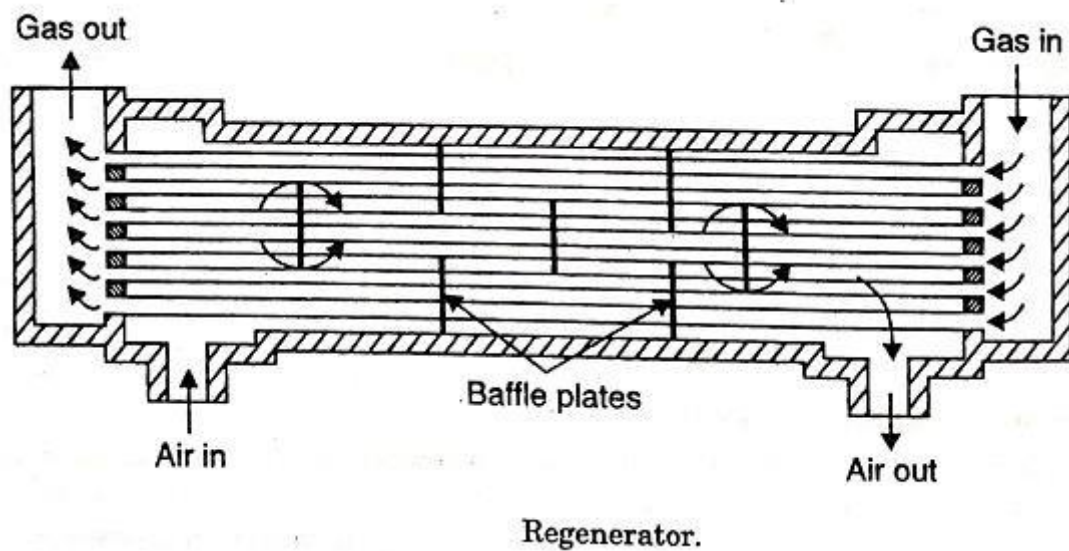

Merits And Demerits Of Gas Turbine Power Plants

A. Advantages over Diesel Plants :

- a. The work developed per kg of air is large compared with diesel plant.
 - b. Less vibrations due to perfect balancing.
 - c. Less space requirements.
 - d. Capital cost considerably less.
 - e. Higher mechanical efficiency.
 - f. The running speed of the turbine (40,000 to 100,000 r.p.m.) is considerably large compared to diesel engine (1000 to 2000 r.p.m.).
 - g. Lower installation and maintenance costs.
 - h. The torque characteristics of turbine plants are far better than diesel plants.
 - i. The ignition and lubrication systems are simpler.
-

- j. The specific fuel consumption does not increase with time in gas turbine plant as rapidly as in diesel plants. 11. Poor quality fuels can be used.

Demerits :

- a. Poor part load efficiency.
- b. Special metals and alloys are required for different components of the plants.
- c. Special cooling methods are required for cooling the turbine blades.
- d. Short life.

Applications of Gas Turbine Plants

Gas turbine plants for the purpose of power plant engineering find the following applications

1. To drive generators and supply peak loads in steam, diesel or hydroplants.
2. To work as combination plants with conventional steam boilers.
3. To supply mechanical drive for auxiliaries.

— These plants are well suited for peak load service since the fuel costs are somewhat higher and initial cost low. Moreover, peak load operation permits use of water injection which increases turbine work by about 40% with an increase in heat rate of about 20%. The short duration of increase in heat rate does not prove of any much harm.

— The combination arrangement of gas turbines with conventional boilers may be super-charging or for heat recovery from exhaust gases. In the supercharging system air is supplied to the boiler under pressure by a compressor mounted on the common shaft with turbine and gases formed as result of combination after coming out of the boiler pass through the gas turbine before passing through the economizer and the chimney.

— The application of the gas turbine to drive the auxiliaries is not strictly included under direct electric power generation by the turbines and would not be discussed.

POSSIBLE QUESTIONS

1. Compare operation of gas turbine power plant with thermal power plant.
2. What are various factors which govern the selection of site for a gas turbine power plant?
3. Discuss classification of gas turbines.
4. Explain with a neat sketch, the layout of a gas turbine power plant.
5. Why combined cycle power plant is most suited with gas turbine?
6. Explain construction and working of an open cycle gas turbine power plant.
7. Explain the starting procedure for a gas turbine plant. 8. Explain with a neat sketch working of a closed cycle gas turbine power plant.
9. How the thermal efficiency of a gas turbine power plant can be increased?
10. Discuss the purpose of intercooler and reheater in a gas turbine power plant.
11. What is co-generation? What are its advantages over open cycle operation?
12. Differentiate between co-generation and combined cycle operation.
13. Discuss various types of co-generation schemes with a neat sketch.
14. Why gas turbine blades need cooling whereas in steam turbine no such arrangement is required?
15. Discuss the role of compressor in a gas turbine power plant.

SHORT ANSWER 'TYPE QUESTIONS

1. Name three types of fuels which a gas turbine can use.
 2. Write three applications of gas turbine.
 3. Mention five advantages of gaseous fuel over liquid fuel.
 4. Mention three benefits of co-generation.
 5. What is the function of compressor turbine in a gas turbine power plant?
 6. Compare co-generation and combined cycle operation of a gas turbine.
 7. How cycle efficiency of a gas turbine plant can be increased?
 8. How increase in ambient temperature affects output of gas turbine?
-